

BM111 series are auto focusing cutting head, which are released by Switzerland RAYTOOLS AG in 2017. The product has built-in motor drive unit through the linear driver and the focusing lens can automatically change the position in the range of 22mm. The user can set the focus continuously through the program to complete the rapid perpiercing of thick sheets or other different thickness and material sheets. The product can be equipped with D30 lens group to integrate the light beam. The optimization of optical design and the design of water-cooled allows laser heads stably and chronically to work at high power lasers.

### Features:

- Optimized optical configuration and smooth and efficient airflow design.
- Auto focus ranges +10~-12mm, accuracy is 0.05mm.
- Can be equipped with the D30 lens group, the maximum fiber input power is 3.3KW.
- Maximum acceleration of focus lens drive 10m/s<sup>2</sup>, maximum speed 10m/min.
- Adds an upper protective lens to the collimator, minimizing the risk of contamination of the collimator.
- Drawer-type of lens mount, quick and easy access to the cover glass.
- With a variety of optical interfaces, can be adapted with a variety of fiber lasers.

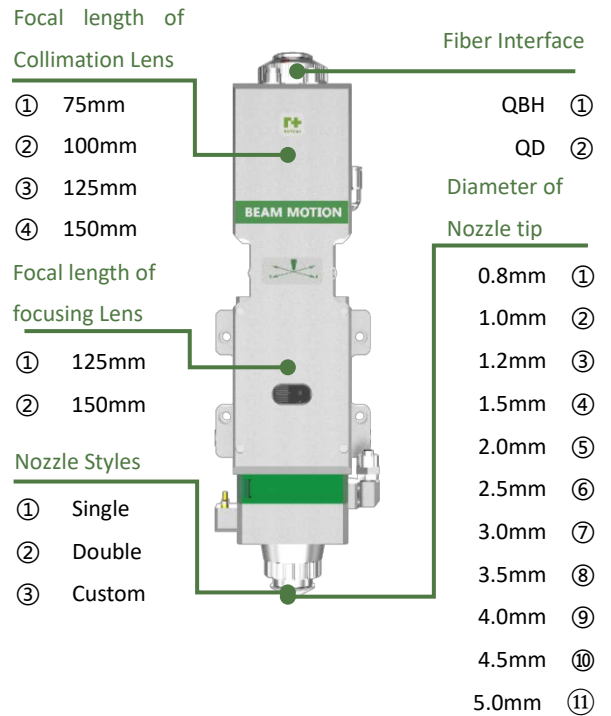

### Specifications:

Cutting Head	
Power Rating	≤3.3KW
Clear Aperture	28mm
Collimation protective glass	φ24.9mm*1.5mm
Focusing protective glass	φ27.9mm*4.1mm
Auto focus range	+10~-12mm
Assist gas Pressure	≤30bar
Weight	~6.5Kg

\* Specifications subject to change without notice.