

## AX3000 Series

---

### Motion Control System of Laser Cutting – User Manual

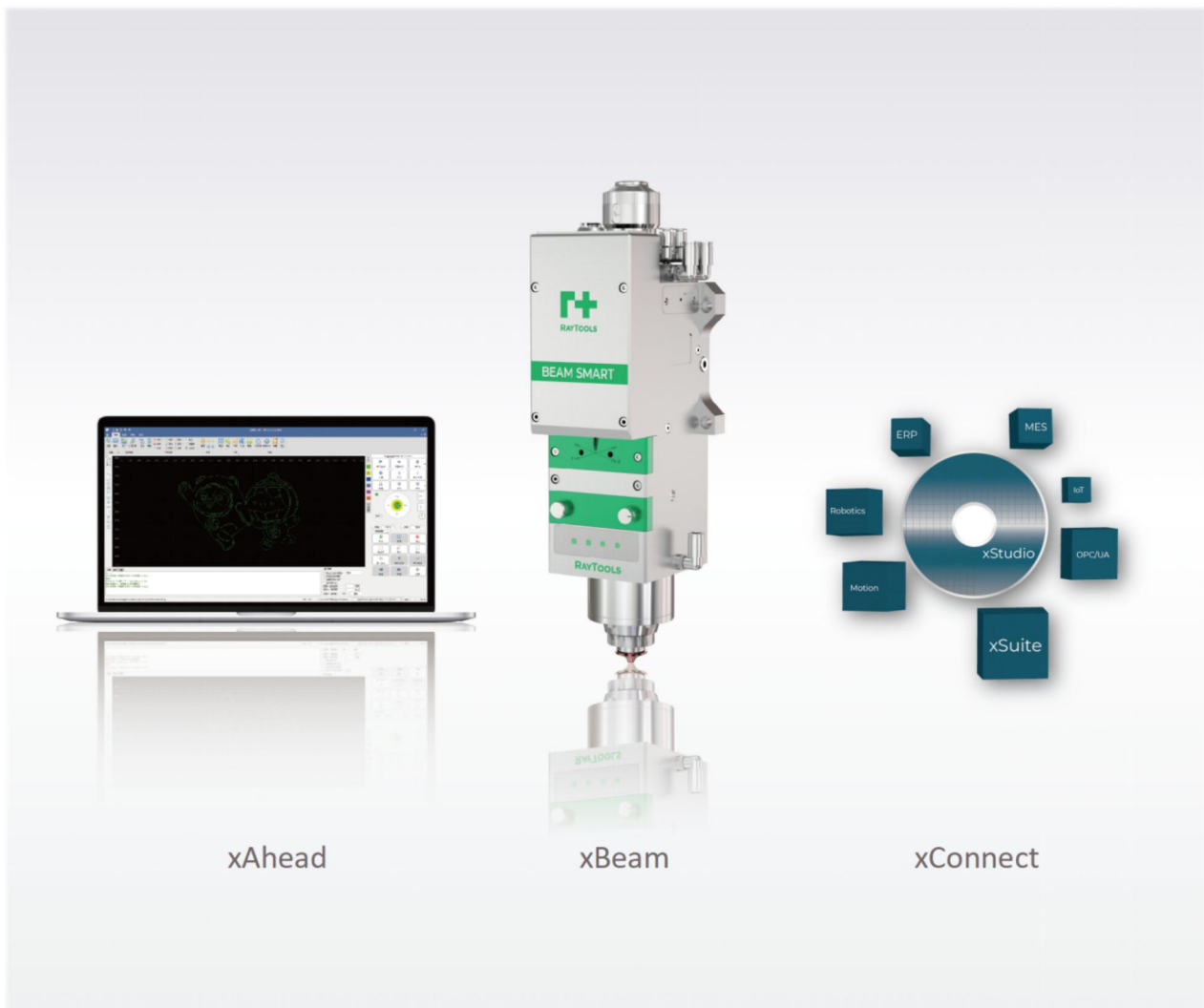

Thank you for choosing this product from *Raytools*!

The manual provides a detailed introduction to the installation and use of the AX3000 Series professional motion control system of laser cutting, including a quick start, introductions to the function, notes and more. The software must be used with a dongle. If you do not have a dongle, you can use a simulator.

Please read the manual in detail before using the software and the associated equipment, as this will help you to use it better.

Due to the constant updating of functions, the product you receive may differ in some respects from instructions in the manual.

We reserve all rights in this document including the issued patents and other registered commercial ownership related to this document. It is strictly prohibited to use this document improperly especially to copy and disseminate it to third parties.

If there is any error in the document, please inform us as soon as possible.

The data contained in this manual is only used to describe the product and shall not be regarded as a statement of security interest.

For the benefit of our customers, we will constantly try to ensure that the products we develop comply with the latest technology.

**Raytools AG**

Email: [sales@raytools.com](mailto:sales@raytools.com)

Website: [www.raytools.ch](http://www.raytools.ch)

## Disclaimer

- We will not bear any responsibility for losses and accidents caused by wrong operation or improper handling of our products.
- Dismantling of the product will lose all warranty claims excluding the normal replacement of worn parts and components required for maintenance or commissioning operations.
- Unauthorized modification of products or use of non-original spare parts will directly lead to the invalidation of warranty and liability exemption.
- It is recommended to only use the spare parts provided by us or submit them to our designated professional team for installation.

## Use Regulations



- Ensure that the product is used in a dry environment.
- Ensure that the product is used in the environment required by EMC standards.
- The product is only allowed to run within the parameters specified in the technical data.

## Personnel Responsibilities

- Be familiar with the basic provisions of work safety and accident prevention, having received equipment operation guidance.
- Read and understand basic safety instructions and operations.
- Must have studied the relevant regulations and safety instructions and understand the possible hazards.
- Comply with relevant regulations and implement corresponding protective measures.

## Safety Instructions

### Prevent Electric Shock

-  Parts of the laser head such as the nozzle, sensor, sensor interface, and attached fasteners may not be fully protected by the ground wire due to function fault. These parts may have low voltage. When installing electrical equipment, please pay attention to taking anti electric shock measures for relevant personnel.
-  Note that the equipment shall be grounded as specified.

### Guard against Danger

- Never put your hands or other body parts in the activated machine.
- Repair and maintenance can only be carried out after power off.
- Must ensure the machine is in normal condition at all times.
- All fasteners such as bolts and nuts must be tightened.

## Contents

<b>1</b>	<b>Quick Start .....</b>	<b>1</b>
	1.1 Start Using .....	1
	1.1.1 Open the Software .....	1
	1.1.2 User interface .....	1
	1.1.3 Toolbar .....	2
	1.1.4 File Menu .....	3
	1.2 Operation Flow .....	4
	1.2.1 Find the Origin .....	4
	1.2.2 Calibrate .....	5
	1.2.3 Import and Optimize Graphic .....	5
	1.2.4 Set Process .....	7
	1.2.5 Plan Cutting Path .....	9
	1.2.6 Check before Process .....	10
	1.2.7 Actual Processing .....	10
<b>2</b>	<b>Graphic Operation .....</b>	<b>12</b>
	2.1 Home .....	12
	2.1.1 Select .....	12
	2.1.2 Display .....	16
	2.1.3 NC Code .....	17
	2.1.4 Scale .....	17
	2.1.5 Transform .....	19
	2.1.6 Leadline .....	20
	2.1.7 Clear .....	21
	2.1.8 Start Point .....	22
	2.1.9 Zero Ref .....	23
	2.1.10 Compensate .....	23
	2.1.11 Outer Cut .....	25
	2.1.12 Inner Cut .....	25
	2.1.13 Ring Cut .....	26

---

2.1.14 MicroJoint .....	27
2.1.15 Reverse .....	28
2.1.16 Over .....	29
2.1.17 Relief .....	30
2.1.18 Fillet .....	30
2.1.19 Cooling point .....	31
2.1.20 Sort .....	32
2.1.21 Array .....	34
2.1.22 Group .....	35
2.1.23 Fly Cut .....	36
2.1.24 Co-edge .....	37
2.1.25 Bridge .....	38
2.1.26 Measure .....	38
2.1.27 Optimize .....	39
<b>2.2 Draw .....</b>	<b>41</b>
2.2.1 Line .....	41
2.2.2 Rectangle .....	41
2.2.3 Circle .....	41
2.2.4 Polyline .....	41
2.2.5 Point .....	42
2.2.6 Text .....	42
2.2.7 Clip .....	43
2.2.8 Extend .....	43
2.2.9 Group .....	43
2.2.10 Align and Sort .....	43
2.2.11 Optimize .....	43
<b>2.3 Nest .....</b>	<b>44</b>
2.3.1 Part .....	45
2.3.2 Nesting .....	46
2.3.3 Nesting Parameter .....	47
2.3.4 Advanced Parameter .....	48
2.3.5 Plate .....	49

---

3 Process Parameter .....	50
3.1 Process Parameter Setting .....	50
3.2 Tree-like Process Structure .....	52
3.3 Layer .....	52
3.4 Processing Mode .....	52
3.5 Cutting Parameter .....	53
3.6 Other Parameters .....	53
3.7 Power Curve .....	54
3.8 Piercing .....	55
3.10 Remark .....	57
3.11 Import and Export .....	58
3.12 Global Parameter .....	58
3.13 OK, Cancel and Apply .....	60
3.14 Material Configuration .....	61
4 Control Panel .....	63
4.1 Coordinate System .....	63
4.1.1 Machine Coordinate System .....	64
4.1.2 Program Coordinate System .....	64
4.2 Manual Control .....	67
4.3 Processing Control .....	69
5 CNC Function .....	73
5.1 Simulate .....	73
5.2 Motor Enable .....	73
5.3 Return Origin .....	74
5.4 Detect Edge .....	74
5.5 Arc Detect .....	78
5.6 Focus Test .....	78
5.7 Task .....	78
5.8 Power-on Prompt .....	78
5.9 Maintenance .....	78

---

5.10 Capacitive Sensor .....	79
5.11 Height Sensor .....	80
5.12 Lubrication .....	82
5.13 Dust Removal .....	83
5.14 Setting .....	84
5.15 Forced Reset .....	85
5.16 View Tread Info .....	85
5.17 View .....	85
<b>6 Status Bar .....</b>	<b>86</b>
6.1 Draw .....	86
6.2 Log .....	86
6.3 System .....	87

### 1 Quick Start

#### 1.1 Start Using

##### 1.1.1 Open the Software

Once the software has been installed, the icon will appear on the desktop, as shown on the right.

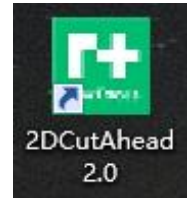

Double-click left mouse button on it to run CNC System: 2DCutAhead 2.0.

##### 1.1.2 User interface

The mainform is one of the most common used user interfaces. There are many operating areas,

as shown below:

- 1: Menu
- 2: Toolbar
- 3: Quick Drawing Toolbar
- 4: Drawing Area
- 5: Control Panel
- 6: Process Toolbar
- 7: Log
- 8: Status Bar

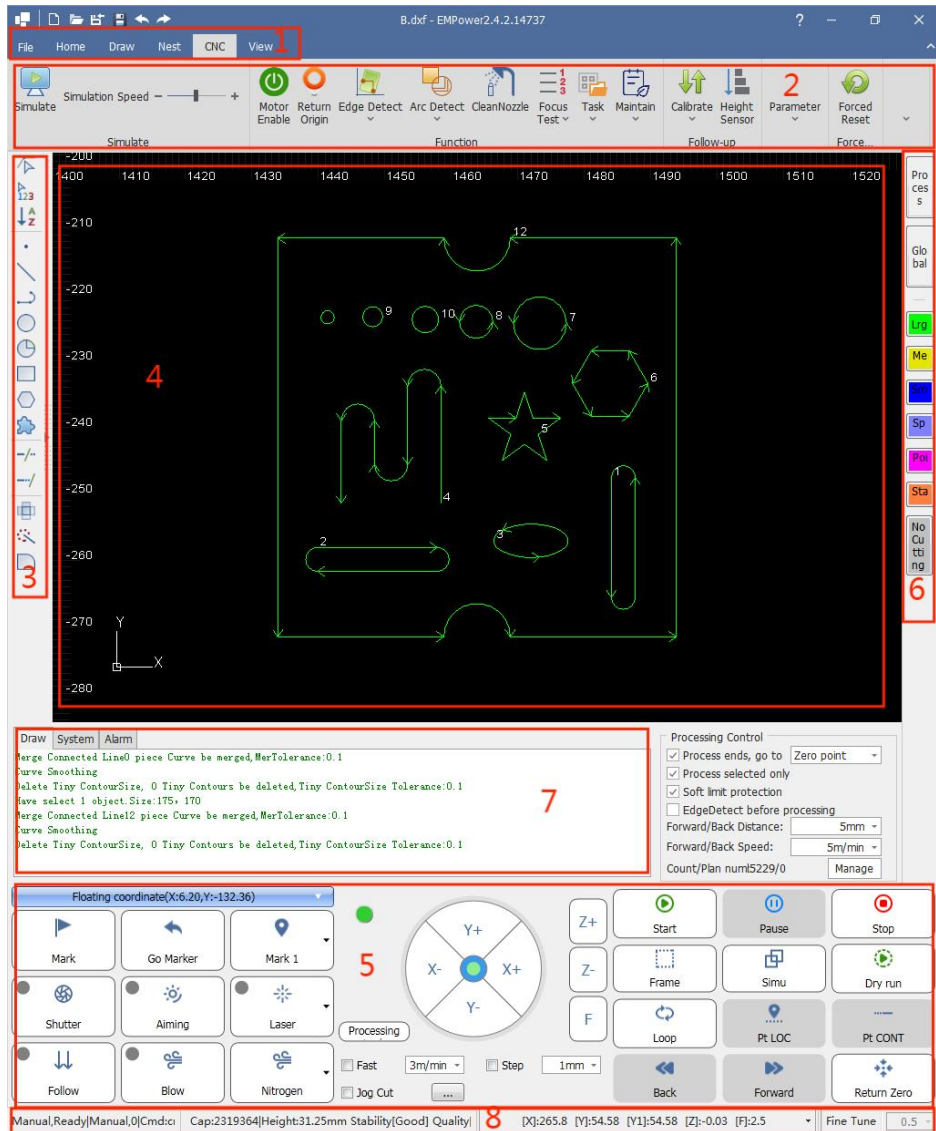



### 1.1.3 Toolbar

As shown below, the toolbar is divided into four sub-pages: "Home", "Draw", "Nest" and "CNC".

Select the sub-page to display its contents. When it is in processing, the "In Processing" page appears and cannot be switched to another page until the process stops.

The toolbar on each sub-page has several "columns" according to functions, such as "View", "Transform", "Process Setting", etc. And each column contains various function buttons.

Please note that some function buttons have a small triangle-type button below which is called 'drop-down button'. Click on it to see more function operation options. If you move the mouse over the function button, it will be shown in a highlighted rectangle.

Click on the top half of button to perform the corresponding function. Click on the bottom part of button to open a 'drop-down bar' which can be single-clicked to perform the corresponding function.

Some columns have a small button in the bottom right corner which is shown as . It is called "expansion button" which can be clicked to open a form with relevant parameters.

Buttons mentioned above are shown in the following figure.

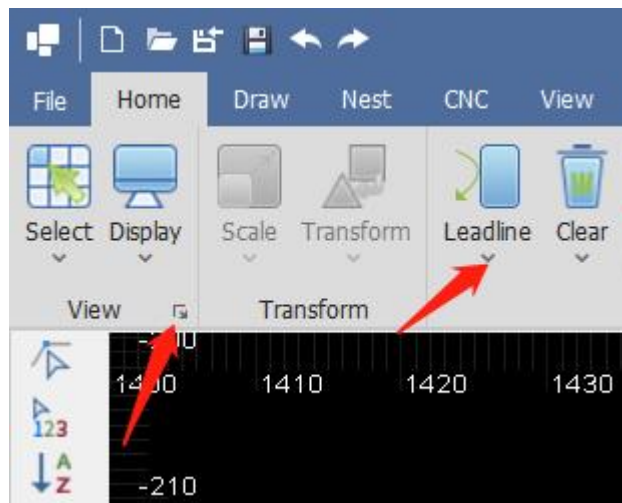

## 1.1.4 File Menu

In the top left corner of the toolbar there is a "File Menu", which contains some file-related options. Click on the  button to open the menu, as shown below.

- **New**  
Create a new drawing and not save the current one.
- **Open**  
Import graphics to be processed. Supported file formats include dxf, emw, nc, nsp, etc.
- **Import**  
Import another file to the drawing board and not clean the existing drawing.
- **Save**  
Save current drawing. Click on the button to select a disc path for saving Supported file formats include dxf, emw, and nc, etc.
- **User Setting**  
Click on the button to set operating habits for auto optimization of graphic import, layer color, advanced parameters, hotkeys and snap, etc.
- **Backup**  
Click on the button to select a disc path for saving the backup of machine parameters.
- **Quick Save Troubleshoot Info**  
Save troubleshoot info. Click on the button to select a disc path for saving.
- **Diagnostic Tool**  
Diagnostic tools mainly include Remote Test, IO Monitor, Capacitive Sensor, Hardware Info, Gas DA Correction, Machine Coordinate Info, Burn-in Test, and Auto Tuning.
- **Installed Tool**  
Factory setting includes ballbar and interferometer.
- **Report**  
Print the processed graphics into a paper file or PDF document.

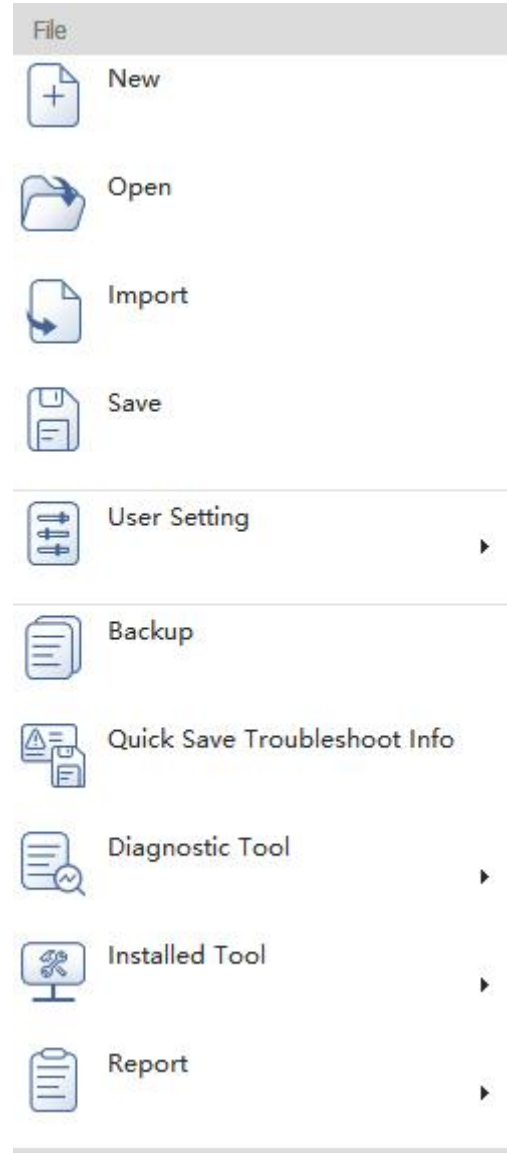

## 1.2 Operation Flow

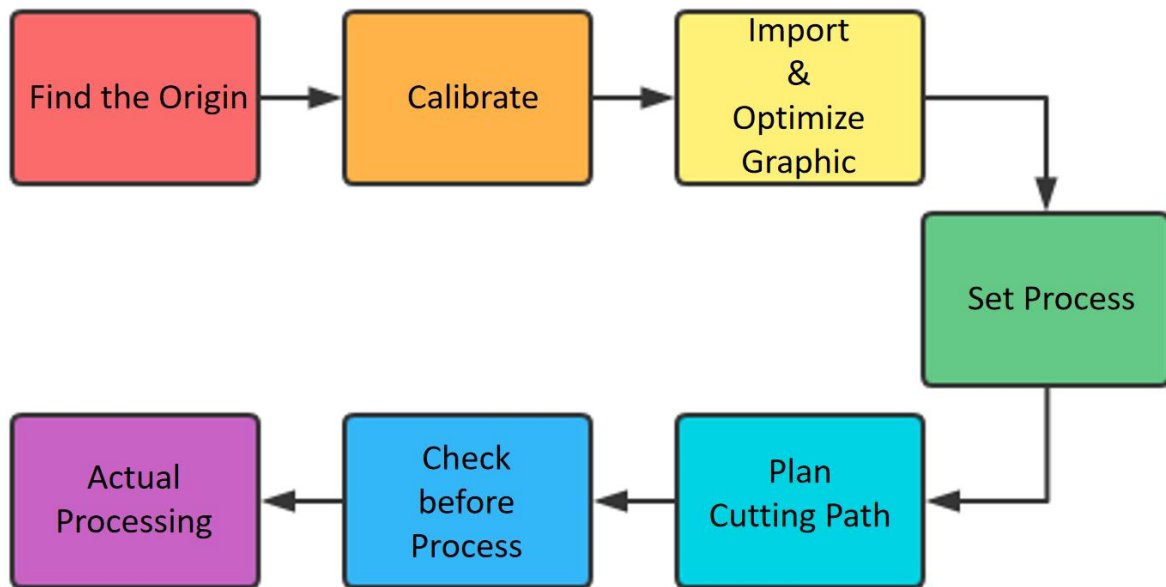

### 1.2.1 Find the Origin

After opening the software, click on Return Origin button in CNC sub-page. Select the axis and set zero (default is to select all axes). Click on Confirm button and wait for the machine to detect the origin, as shown below:

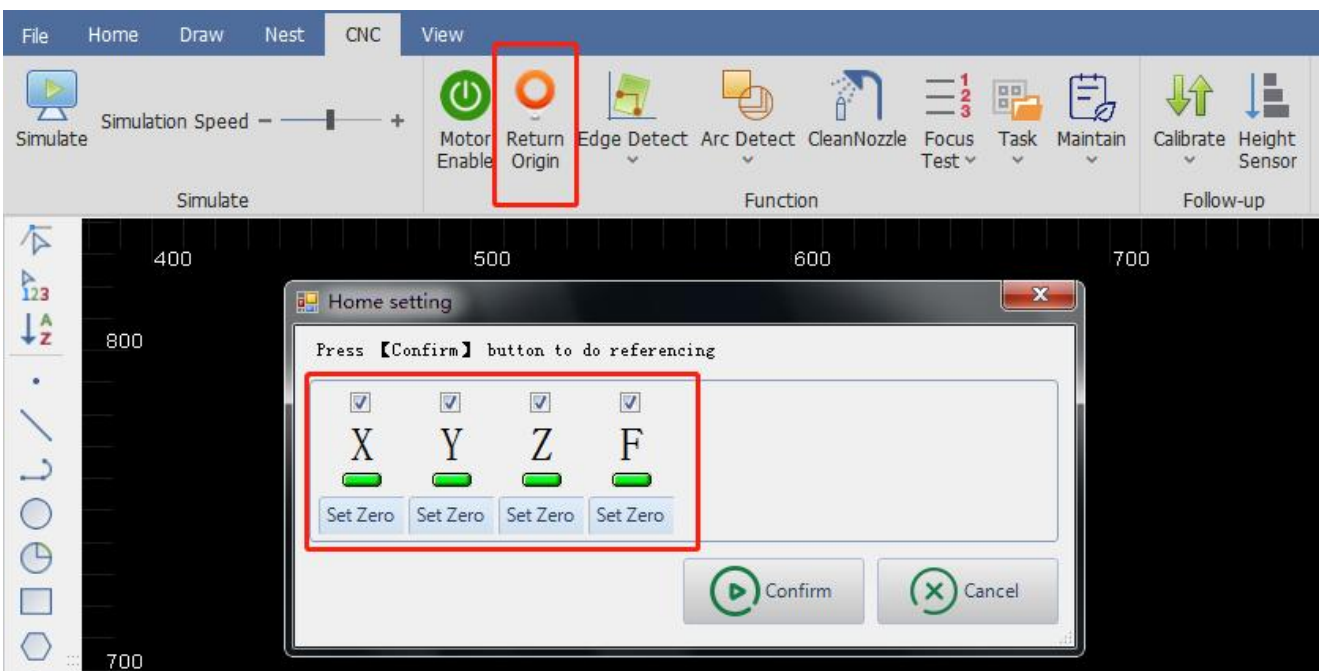

### 1.2.2 Calibrate

After the machine completed returning origin, place the cutting head above the clean flat sheet to be cut.

Click on the drop-down button of Calibrate in CNC sub-page, and then the drop-down bar will pop up. Click on Calibrate button in the bar, as shown below:

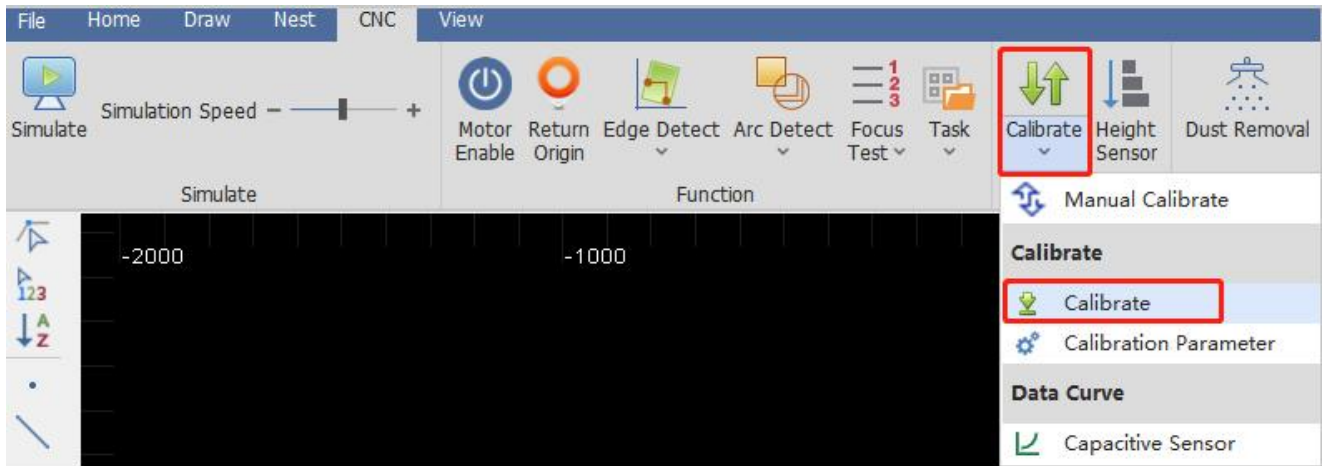

### 1.2.3 Import and Optimize Graphic

After the cutting head has been calibrated, import the graphic to be processed by clicking on Open button in File Menu, as shown below:

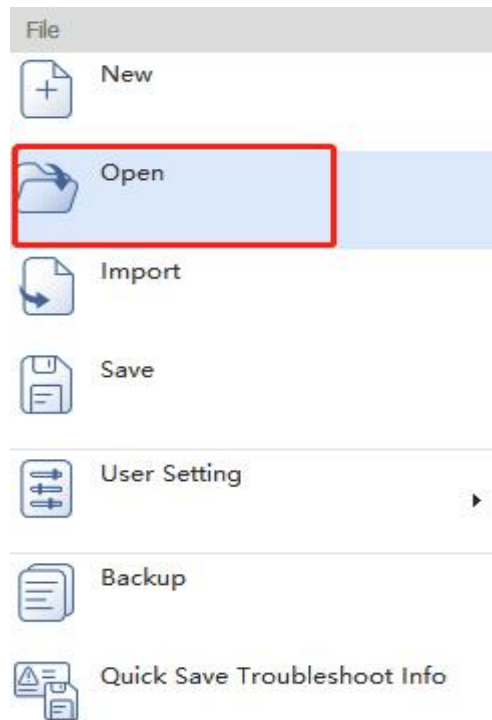

An interface of graphic import will pop up. Select the graphic in the disc and click on Open button. Currently supported file formats include DXF, EMW, NC, and NSP, as shown below:

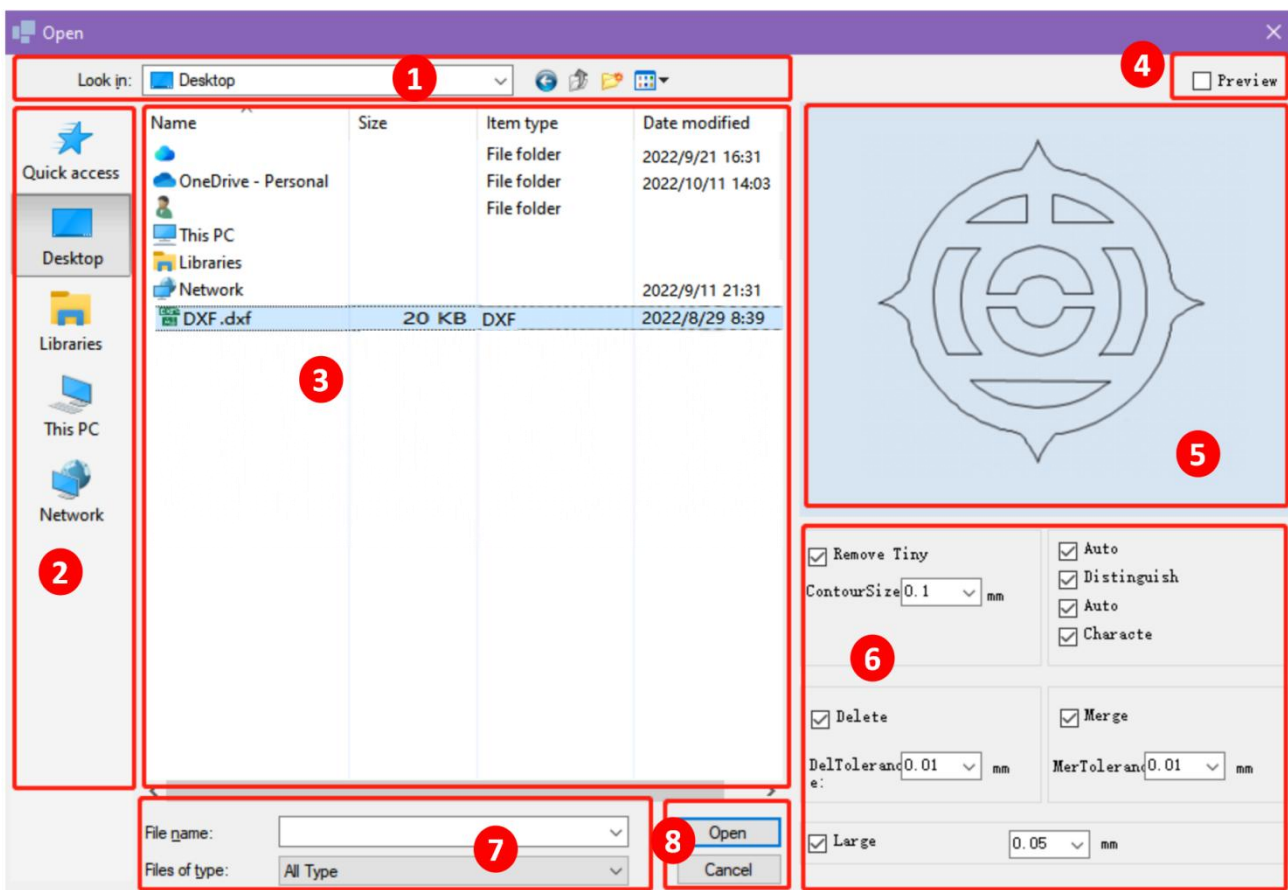

**(1) Current disc path**

Show the current file path.

**(2) Discs**

Select the disc of needed file.

**(3) Files**

Files and folders are shown as complying with the filter criteria by current disc path.

**(4) Preview**

Select to preview the graphic or not.

**(5) Preview area**

Click on Preview button. The graphic in selected file can be displayed.

**(6) Optimize graphic**

After importing, the graphic can be auto-optimized according to options selected and parameters filled in.

**(7) Filter**

Select the file type by the filter.

**(8) Open and Cancel**

Click on Open to import the graphic. Click on Cancel to cancel the importing.

**1.2.4 Set Process**

After the graphic import is completed, some functions in the Process Setting in Home sub-page may be needed. Functions are shown below:

- **Leadline:** add to enable the workpiece to avoid being incomplete which may be caused by piercing.
- **Start Point:** set the start point of graphic processing.
- **Micro Joint:** insert small segments not to be cut in the graphic to avoid the part falling.
- **Compensate:** compensate the cutting slot.
- **Reverse:** set processing direction of the graphic (clockwise or anticlockwise).
- **Cooling Point:** protect the workpiece corners to be complete.

Change the processing layer of graphic.

(1) Select the graphic which needs to change a layer.

(2) There is a process bar on the right of the drawing area. Click on Layer buttons to complete the change of processing layer. In the drawing area, colors of the layer can be used to distinguish them.

Click on Process button to set process parameters for the current graphic. Then click on OK, as shown below:

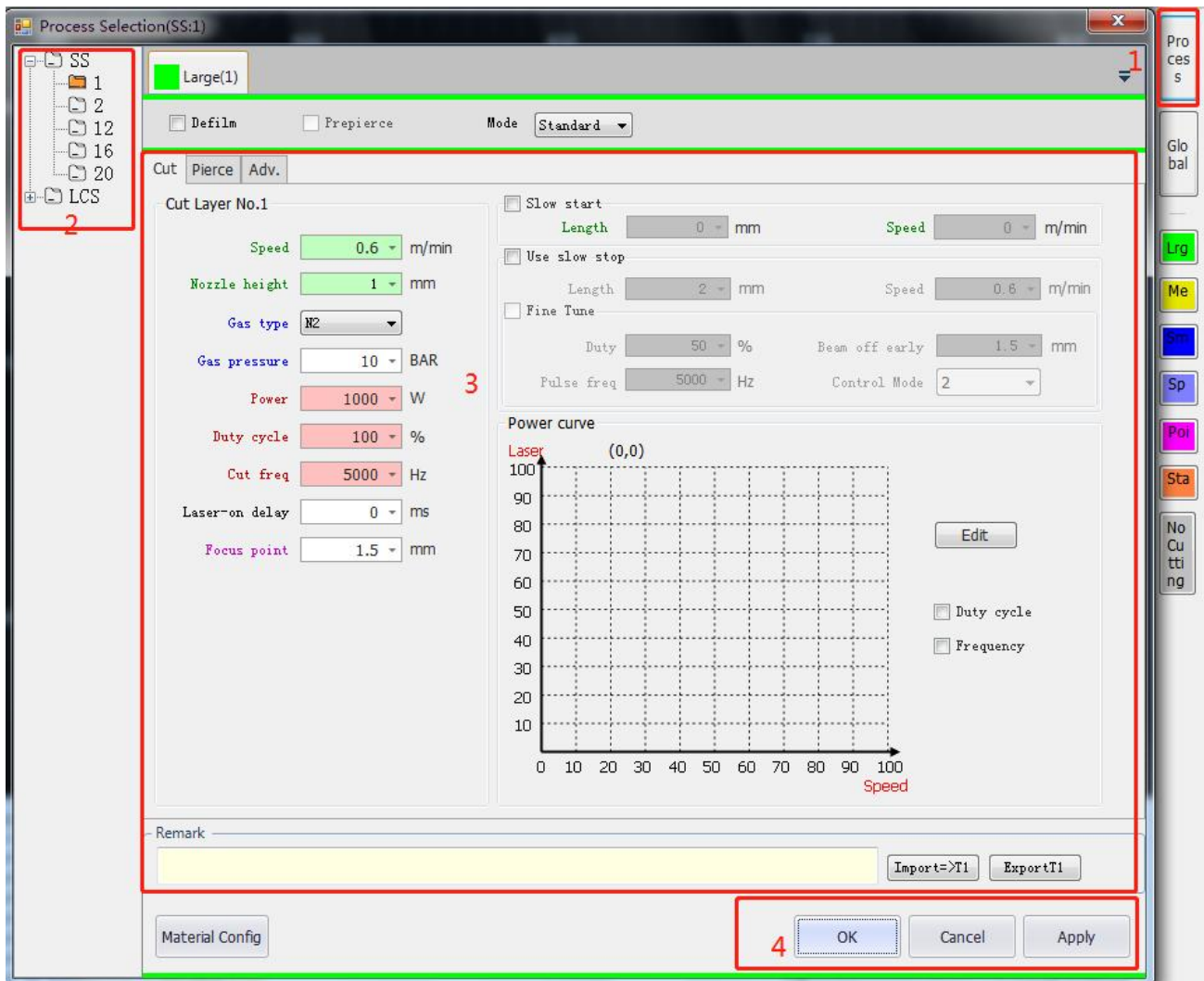

- (1) Click on Process button and enter the setting page of process parameters.
- (2) Select the sheet material and thickness.
- (3) Set process parameters of the current graphic.
- (4) Complete setting and click on OK.

If you need to save process parameters of current layer, click on Export to save them as a file. Then, you only need to import the layer process parameters, select the material thickness, and click OK.

### 1.2.5 Plan Cutting Path



This step is to sort the graphics to be processed. Click on  button in Home or Draw sub-page to auto sort the



graphics. Click the drop-down button, , of Sort to see there are several ways. Select one according to your need. It is shown below:

- ✓ Smart Sort
- Grid Pattern
- Local Shortest Path
- Layer Sort
- Smaller Vector Prior
- Left to Right
- Right to Left
- Top to Bottom
- Bottom to Top
- Arc Sort
- Manual Sort ▶



You can also group the graphics by selecting the graphics to be grouped and clicking on  button in Home or Draw. Graphics in the selected group will be a whole and the processing sequence fixed. Later sorting will not affect the processing sequence in current group.



## 1.2.6 Check before Process



After sorting the graphics, check the cutting path by clicking on **Simulate** button in CNC sub-page or Simu in the control panel. The graphic will start simulated processing in the drawing area. In CNC sub-page, the speed of simulation

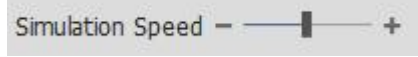

can be adjusted. Check the sequence of graphics by simulation.

## 1.2.7 Actual Processing

Please note that in this step, the machine tool will start running. Operate with caution!

For preparation, click on **Preview** button in the control panel. The graphics are in the drawing area. Confirm the workpiece on machine tool complying with the graphic and the position of cutting head to graphic in drawing complying with the actual position of cutting head to the sheet. Know about their positions with the icons displayed in the drawing area, as shown below:

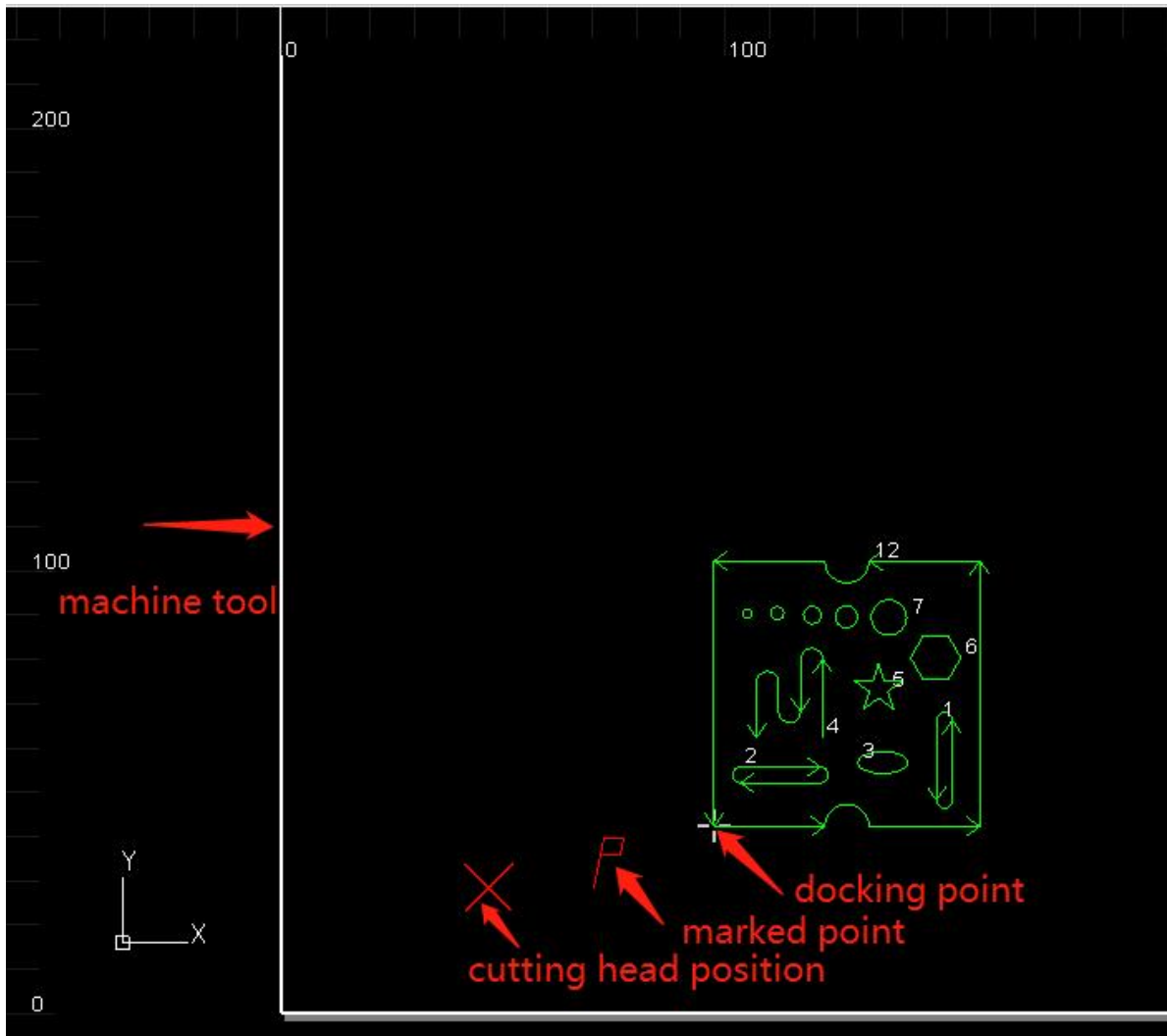

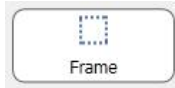

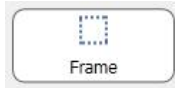
After checking the previous steps, click on  button and the cutting head will run along the outer part of the graphic. It can be used to check the actual processing position and if there is any obstacle, etc.



When there is no problem, click on  button for rechecking to make the cutting head to run along the cutting path of the graphic without optical beam or gas out.





After dry running with nothing wrong, click on  button to make the cutting head start processing with beam and gas on.





In processing, click on the  button to pause the processing. After paused, you can manually control the cutting head to rise and descent, blow gas, and so on.



Click on  or  button to make the cutting head move forward or backward along the cutting path.



Click on  button to continue cutting along the path. Click on  button to stop the processing.



If the machine is stopped with workpiece unprocessed or no change to the graphics, click on  button to



locate the breakpoint and move the cutting head elsewhere. Click on  button to move the cutting head back to the position where it is stopped and continues processing.

## 2 Graphic Operation

### 2.1 Home

#### 2.2.1 Select

There are various ways to select graphics. Basic operation is to click on the graphic contour. Another way is box selection. Left click and hold the mouse. Then, drag it to create a translucent box to select the graphic.

There are two types of box selection. When drag the mouse from left to right, only the graphic completely covered in the selection box will be selected. When drag the mouse from right to left, once part of the graphic is in the box, the graphic will be selected. You may use both types flexibly up to your need.

Click on Select in Home sub-page, and the drop-down bar will pop up. There are more advanced options, as shown below:

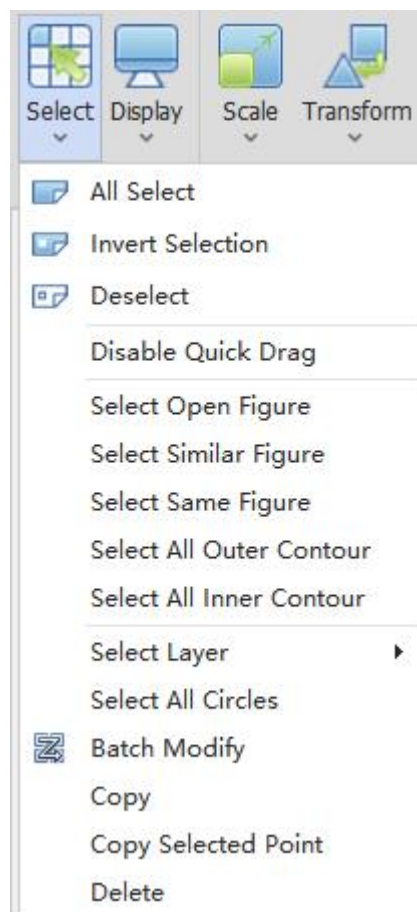

- (1) **All Select:** select all the graphics in current drawing.
- (2) **Invert Selection:** change current selected graphics into unselected.
- (3) **Deselect:** deselect the selected graphics.
- (4) **Disable Quick Drag:** make the graphics in current drawing area can not be dragged.

(5) **Select Open Figure:** select all the open graphics in the drawing area, as shown below:

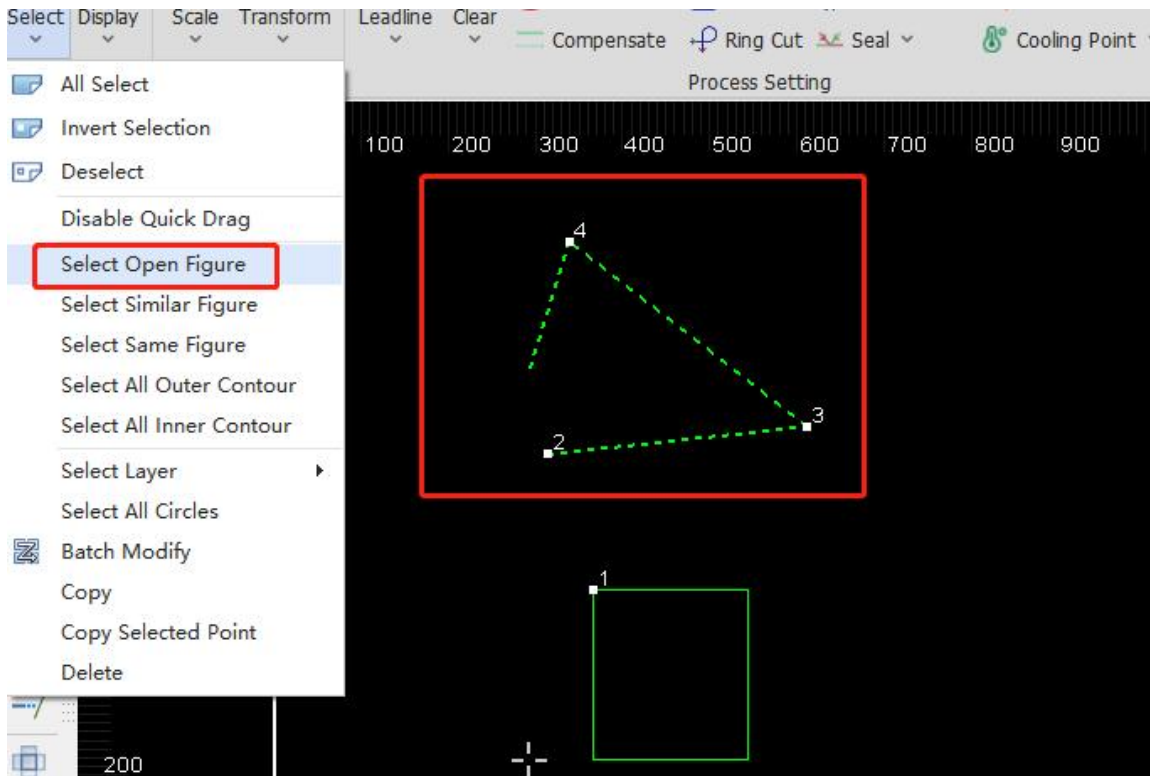

(6) **Select Similar Figure:** select all similar graphics in the current drawing, as follows:

- a. Select a target graphic (squares and circles are shown in below figure as an example),
- b. Click on Select Similar Figure,
- c. All squares and circles of the same size in the drawing are selected.

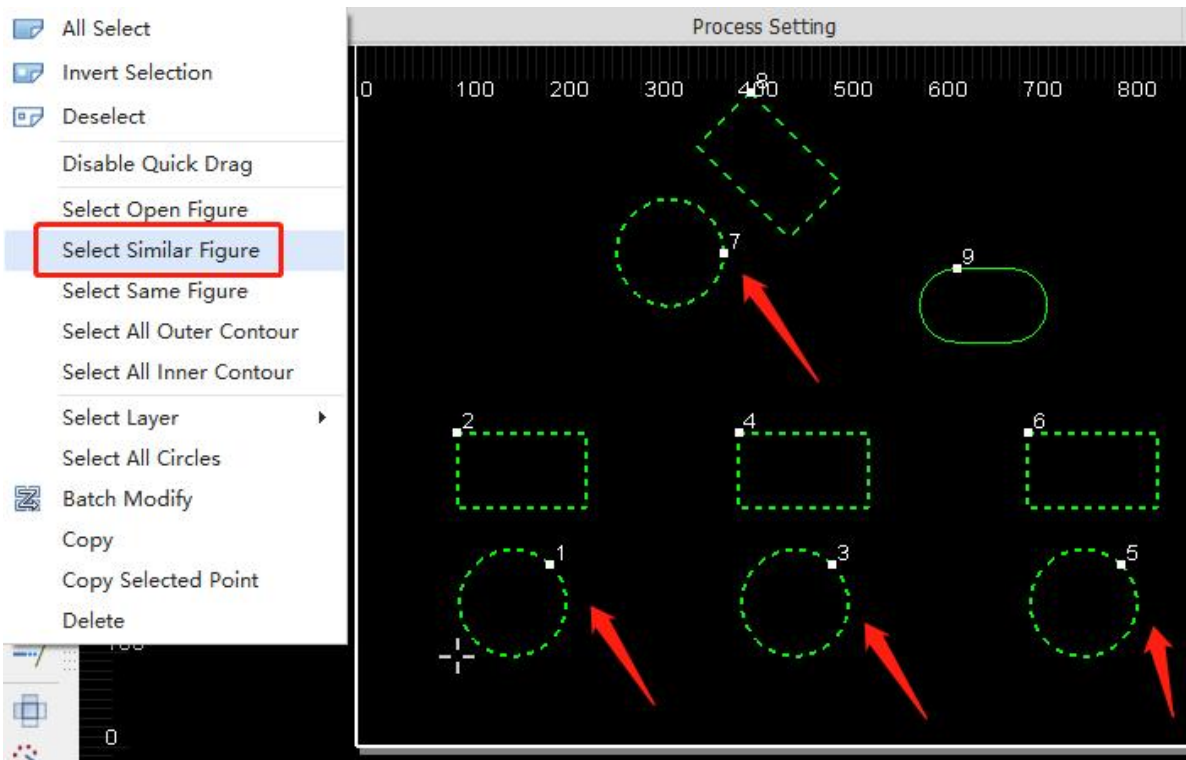

**(7) Select Same Figure** (same angle): select all the same graphics in the current drawing, as follows:

- a. Select a target graphic (squares and circles are shown below as an example)
- b. Click on Select Same Figure
- c. All squares and circles of the same angle and size in the drawing are selected.

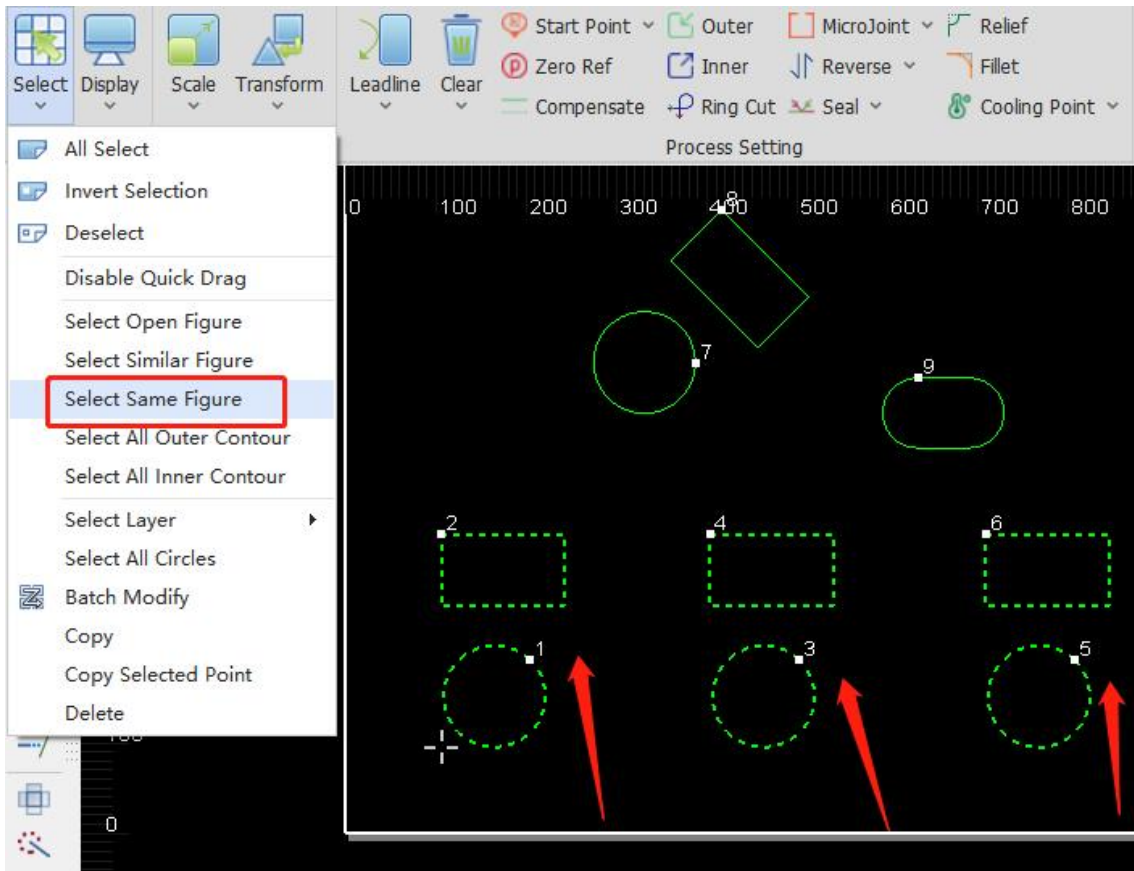

**(8) Select All Outer Contour:** select all outer contours in the current drawing, as follows:

Click on Select All Outer Contour and all outer contours in the current drawing are selected, as shown below.

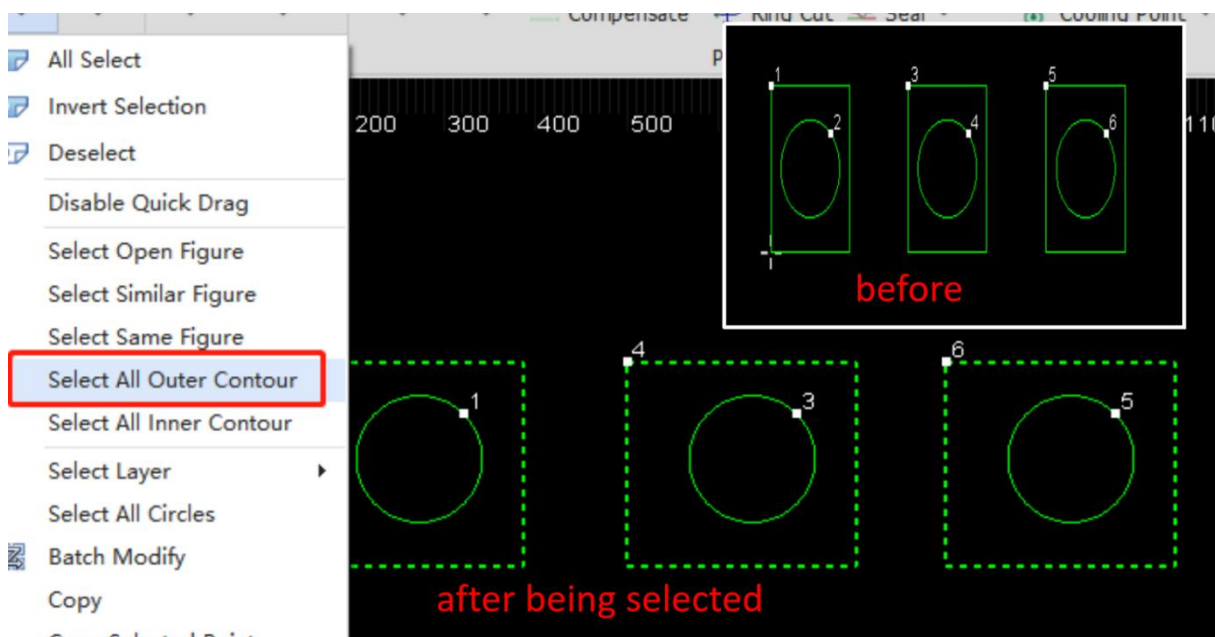

**(9) Select All Inner Contour:** select all inner contours in the current drawing, as follows:

Click on Select All Inner Contour and all inner contours in the current drawing are selected, as shown below:

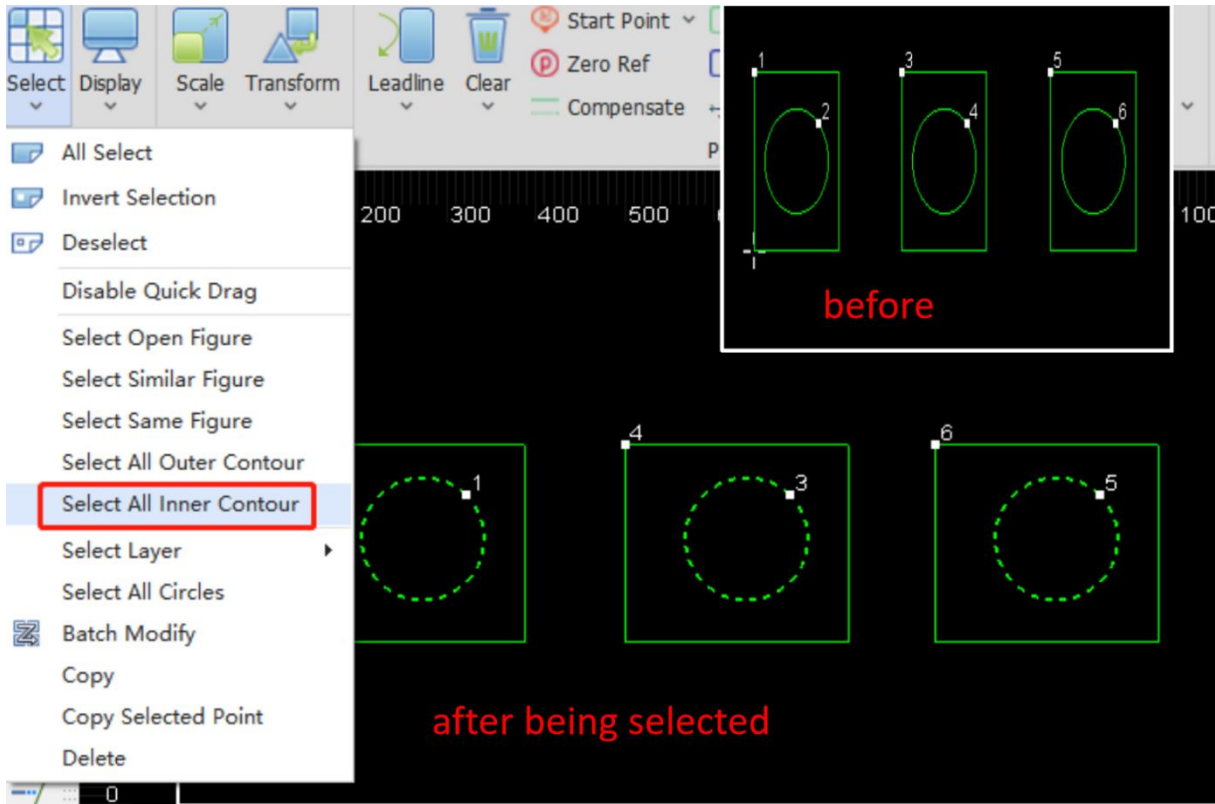

Tip (of the inner and outer contour): the contours are distinguished by their positional relationship. The outermost is the outer contour; the next is the inner contour; then, the outer one, and so on. Open graphics have no contour.

**(10) Select Layer:** select all layers in the current drawing, as follows:

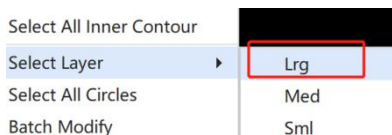

Click on **Lrg** and all outer large contours in the current drawing are selected.

Select other layers by other options.

**(11) Select All Circles:** select all circles in the current drawing, as follows:

Click on Select All Circles and all circles in the current drawing are selected.

**(12) Copy:** copy the graphic, as follows:

Select the graphic needs to be copied in current drawing. Click on Copy. Drag the graphic copied to the proper position and click on it.

**(13) Delete:** delete the graphic, as follows:

Select the graphic needs to be deleted in current drawing. Click on Delete and the graphic selected will be deleted.

## 2.1.2 Display

Click on Display button in the Home sub-page, and the drop-down bar will pop up, as shown below:

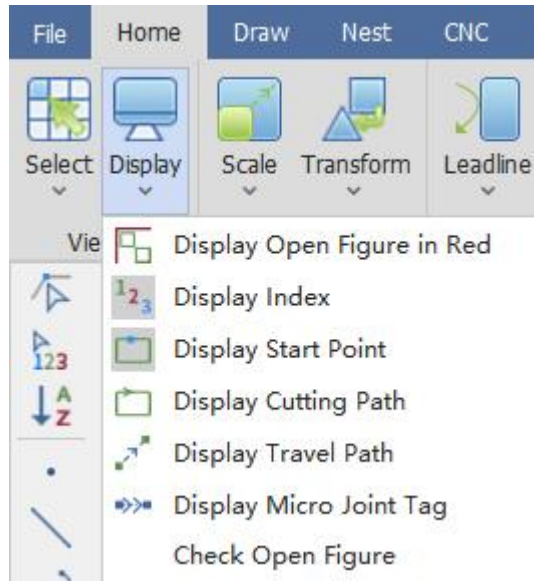

- (1) **Display Open Figure in Red**: change the current open graphics into red.
- (2) **Display Index**: display the sequence of graphics in current drawing.
- (3) **Display Start Point**: display the start point of graphics in current drawing.
- (4) **Display Cutting Path**: display the cutting path of graphics in current drawing by their contours.
- (5) **Display Travel Path**: display the travel path between the end of one graphic and the start of next graphic.
- (6) **Display Micro Joint Tag**: display clear marks of the micro joint used in the graphic in current drawing. Once the display functions have been completely turned on, it shows as below:

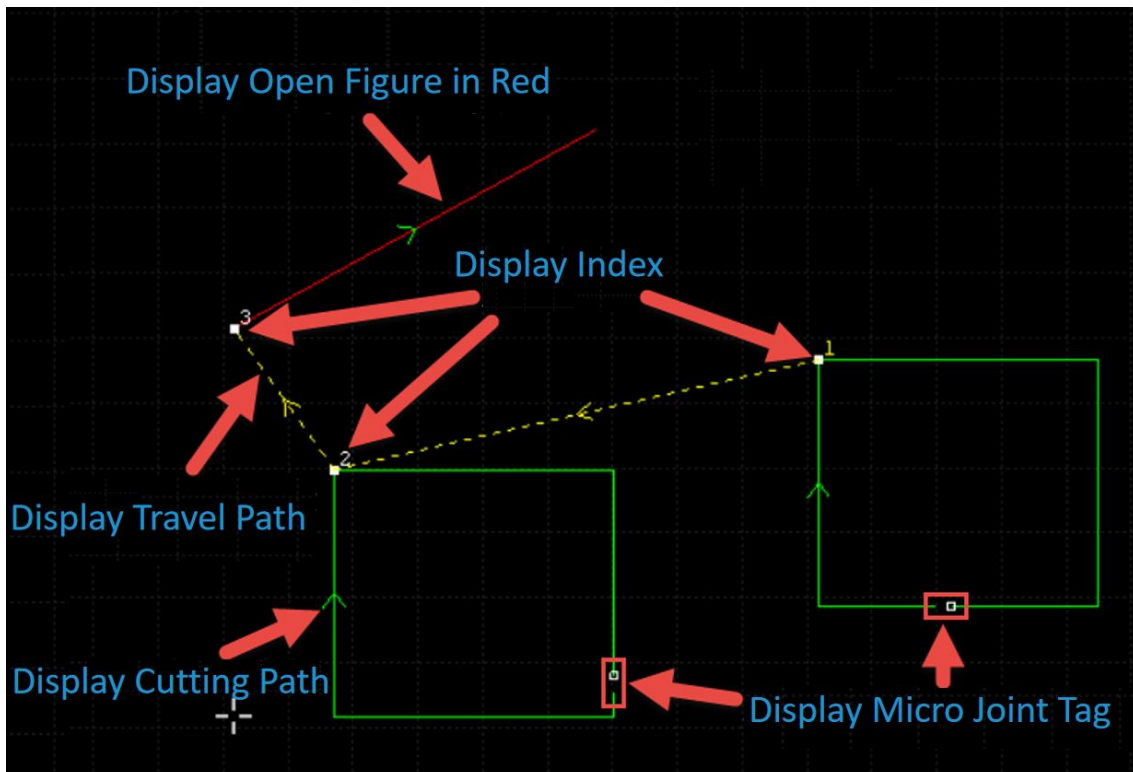

2.1.3 NC Code

Click on the button to view the current graphic in processing, NC code and process parameters in the pop-up interface, as shown below:

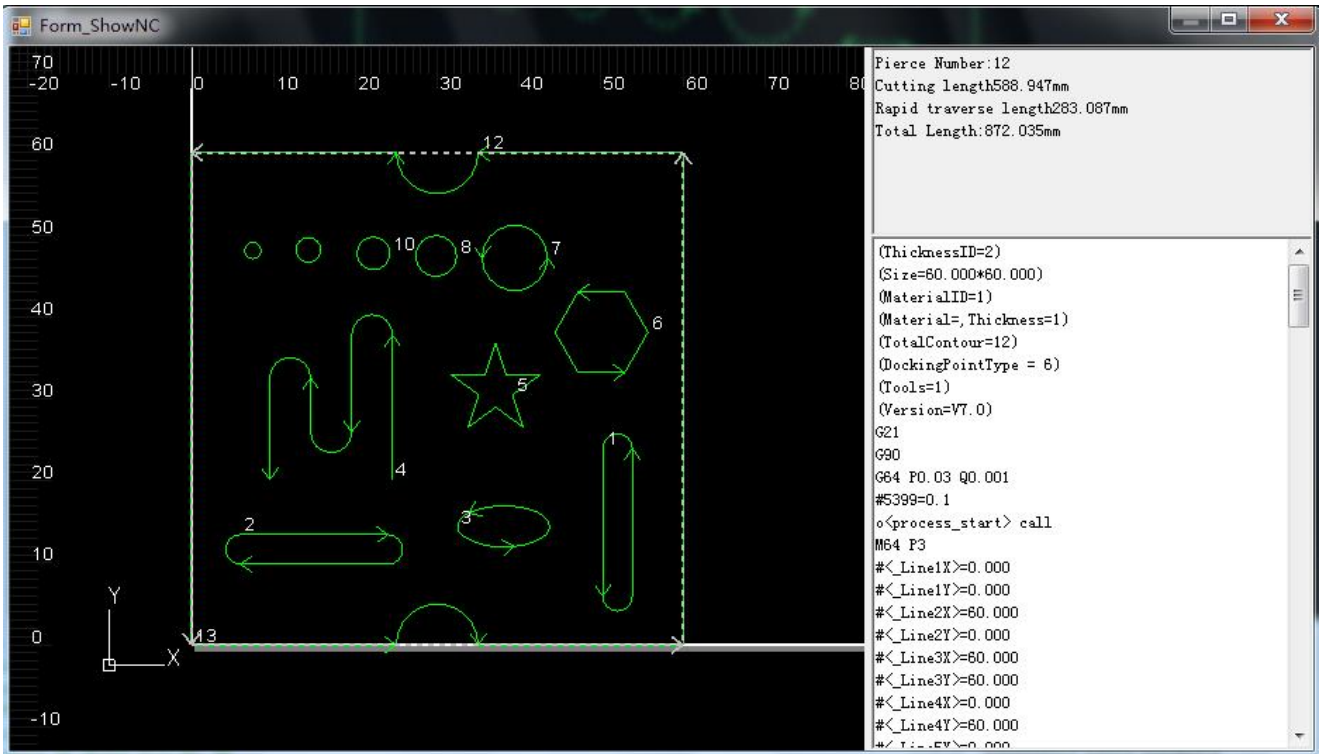

2.1.4 Scale



Select the graphic and click on the drop-down button under the Scale button in Transform function. The drop-down bar displays options to change the size of selected graphic, as shown below:



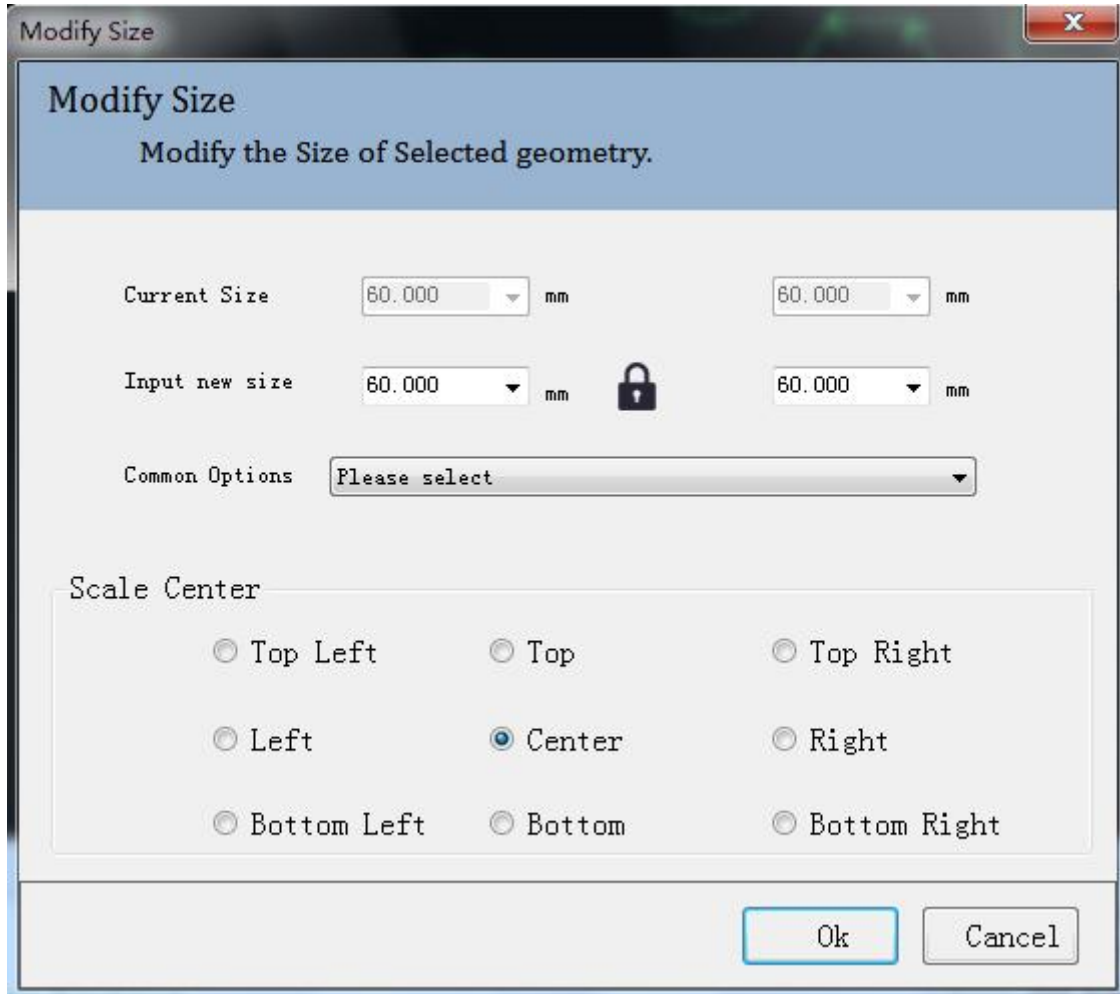

To input accurate sizes, please select the graphic and click on Scale button. You can input a new size and click on OK to complete. The interface is shown as below:



- (1) When the status of the lock in the interface is , the length and width of the graphic scale according to its original size. To set length and width individually, click on the button as  to unlock it and enter the needed size.
- (2) Common Options: select the option according to needed size to scale the graphic.
- (3) Scale Center: set the reference point for scaling according to the positional relation of the scaled graphic and the original one.

## 2.1.5 Transform

Click on Transform button in the Home sub-page, and the drop-down bar will pop up, as shown below:

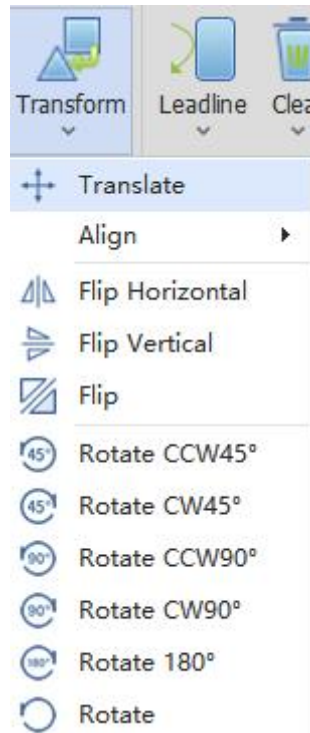

- (1) **Translate:** select the graphic to be translated and click on Translate. In the drawing area, click on one reference point and move the mouse to drag the graphic to any position. Click on anywhere in the drawing area to complete.
- (2) **Align:** select the graphic to be aligned and click on Align to open the expansion bar. There are several types of alignment in the expansion bar. Click on the needed one to complete.
- (3) **Flip Horizontal:** select the graphic to be flipped and click on Flip Horizontal to complete.
- (4) **Flip Vertical:** select the graphic to be flipped and click on Flip Vertical to complete.
- (5) **Flip:** select the graphic to be flipped and click on Flip. Click on anywhere in the drawing area for a reference point. Move the mouse to drag the graphic to any position and click on anywhere to complete, as shown below:

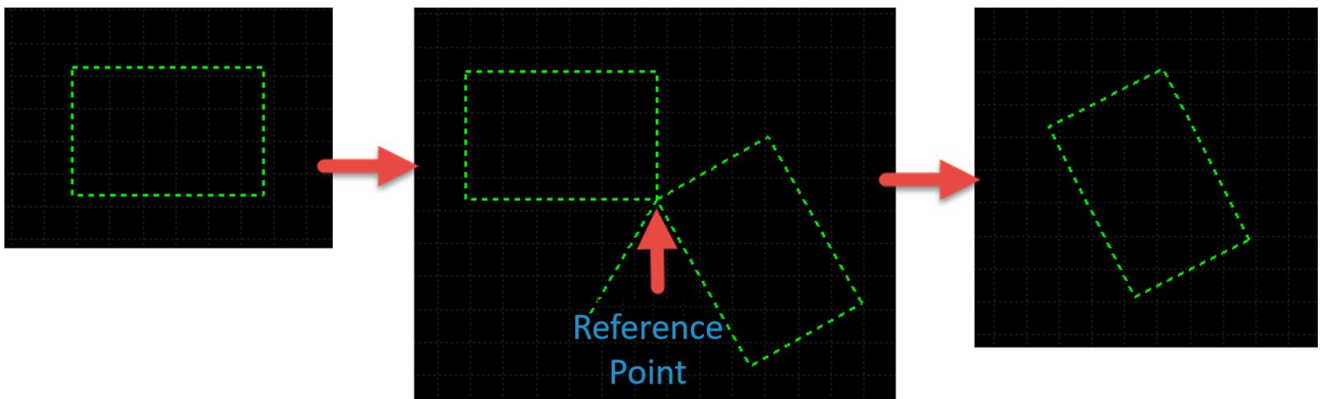

- (6) **Rotate CCW45°**: select the graphic to be rotated and click on Rotate CCW45° to complete.
- (7) **Rotate CW45°**: select the graphic to be rotated and click on Rotate CW45° to complete.
- (8) **Rotate CCW90°**: select the graphic to be rotated and click on Rotate CCW90° to complete.
- (9) **Rotate CW90°**: select the graphic to be rotated and click on Rotate CW90° to complete.
- (10) **Rotate 180°**: select the graphic to be rotated and click on Rotate 180° to complete.
- (11) **Rotate**: select the graphic to be rotated and click on Rotate. Click on anywhere in the drawing area for a reference point. Move the mouse to drag the graphic to any position and click on anywhere to complete, as shown below:

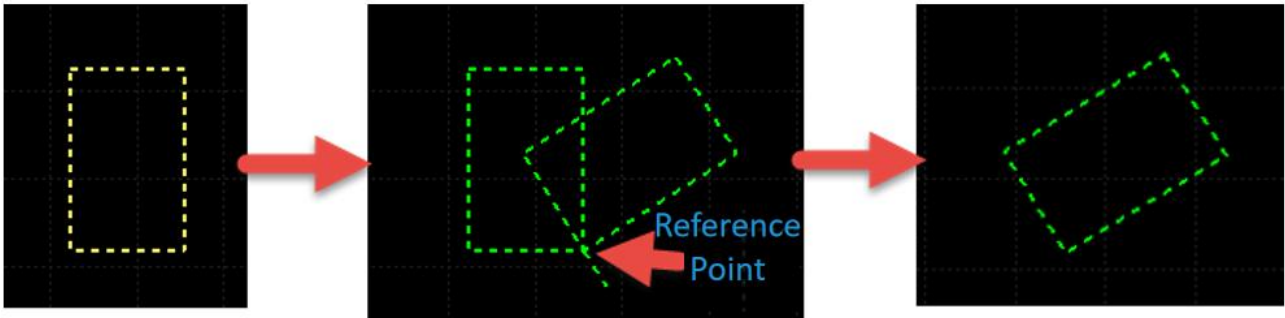

### 2.1.6 Leadline

Add the lead-in and lead-out lines for the selected graphic. Supported types include line, arc, and line + arc. Supported lead-in positions include vertex (On Endpoint), long edge (On Center of Long) and start point (On StartPoint). There are options to choose to use the leadline to the closed graphics and cross-check after added or not, as shown below:

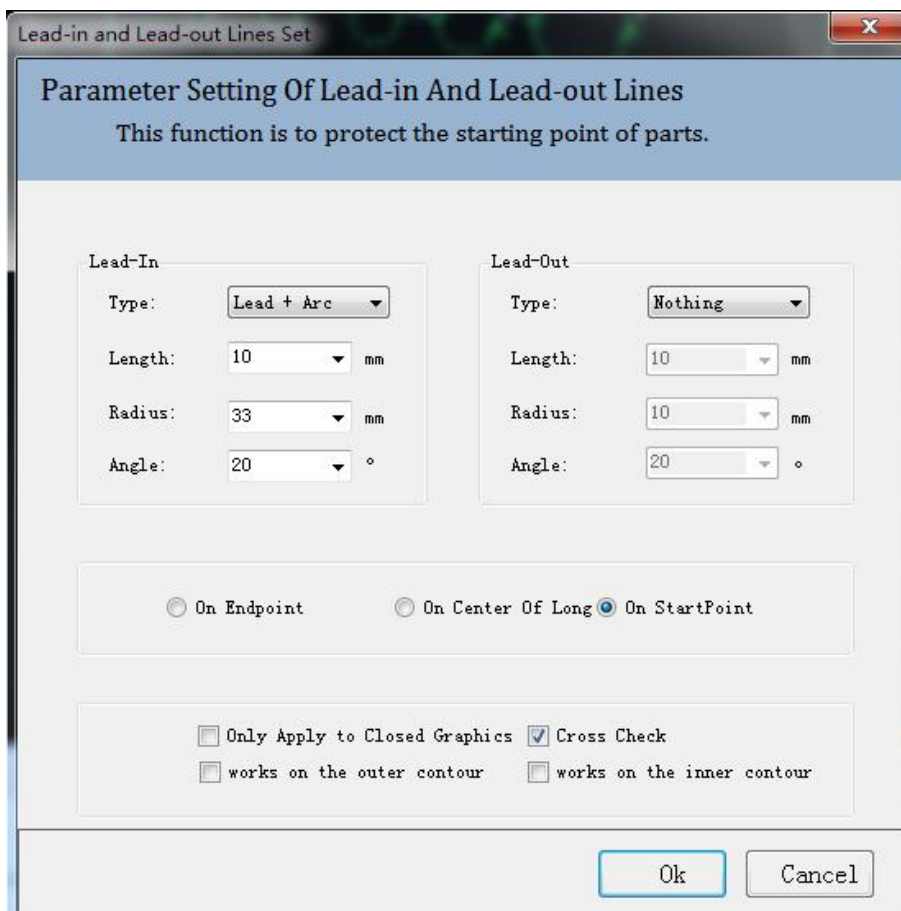

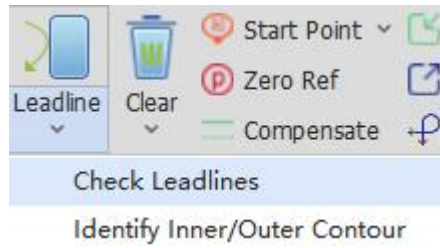

**(1) Check Leadlines:** when the leadline crosses the cutting contour for the leadline is too long, check leadlines to reduce the length to avoid breaking the contour.

**(2) Identify Inner/Outer Contour:** the contours are distinguished by their positional relationship. The outermost is the outer contour; the next is the inner contour; then, the outer one, and so on. Open graphics have no contour.

### 2.1.7 Clear

Click on Clear button in the Home sub-page. Select the graphic and click on the option in the drop-down bar to clear the used function, as shown below:

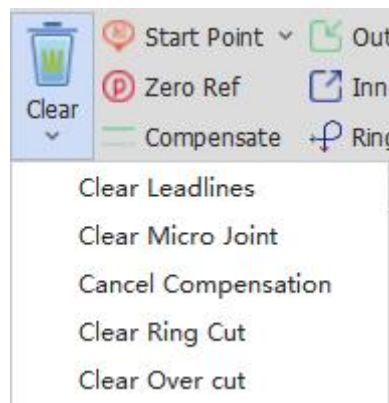

### 2.1.8 Start Point

Set the start point of processing.

Click on Start Point button in the Home sub-page. The drop-down bar contains Manual Start Point and Auto Start Point.

**(1) Manual Start Point:** click on it and select the contour of the graphic to complete setting the start point, as shown below:

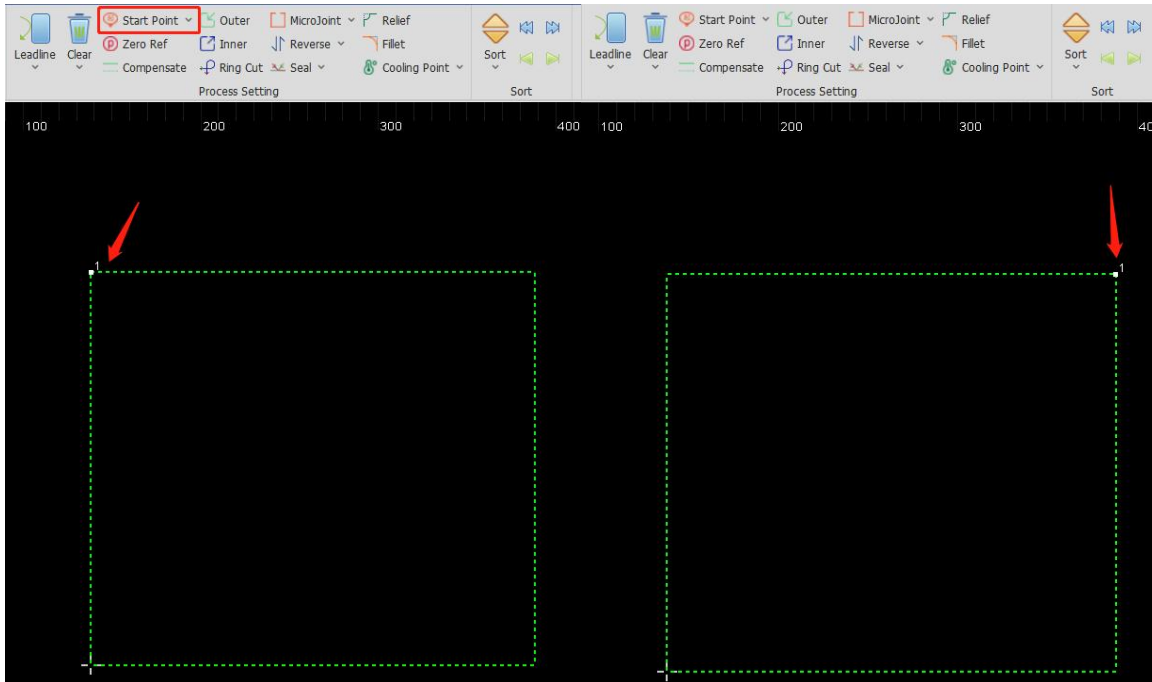

**(2) Auto Start Point:** select the graphic to be processed and click on Auto Start Point. Set the start point in the new interface and click on OK to complete, as shown below:

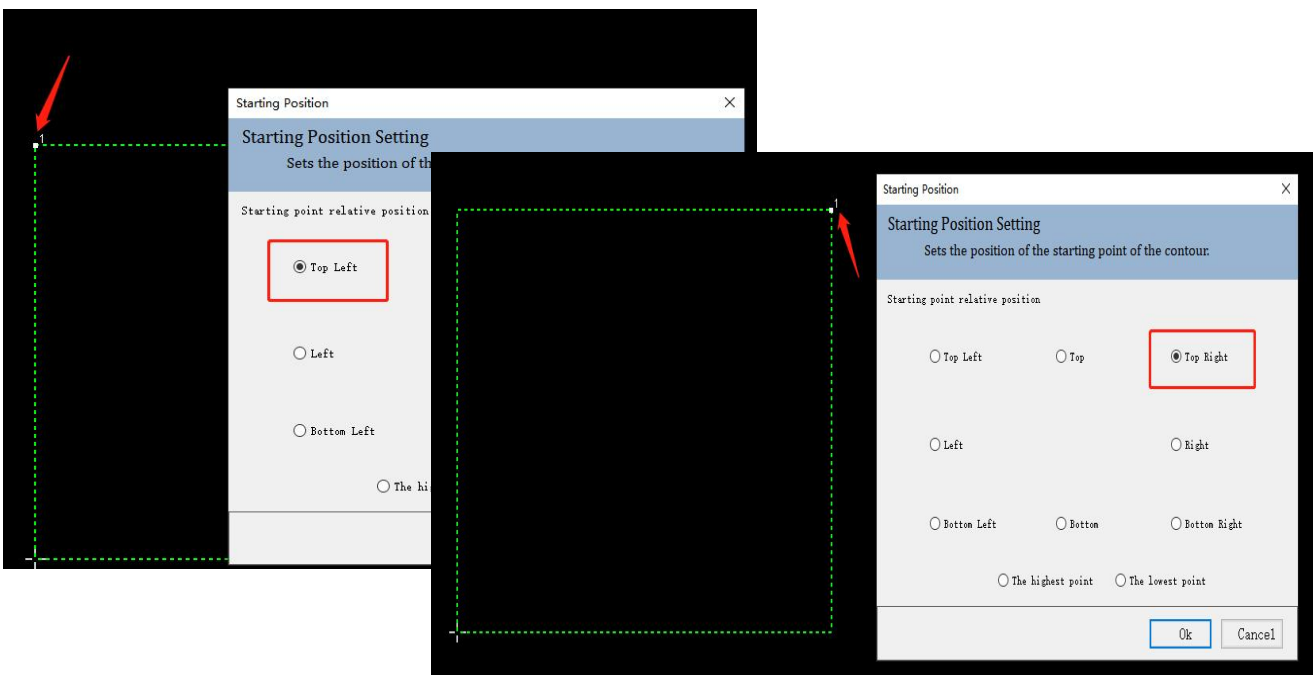

**2.1.9 Zero Ref**

Set the cutting head to a relative position to the graphic as the zero reference (docking position). The bottom left is recommended.

Click on Zero Ref button in THE Home sub-page and set the parameters. After setting, click on OK to complete, as shown below:

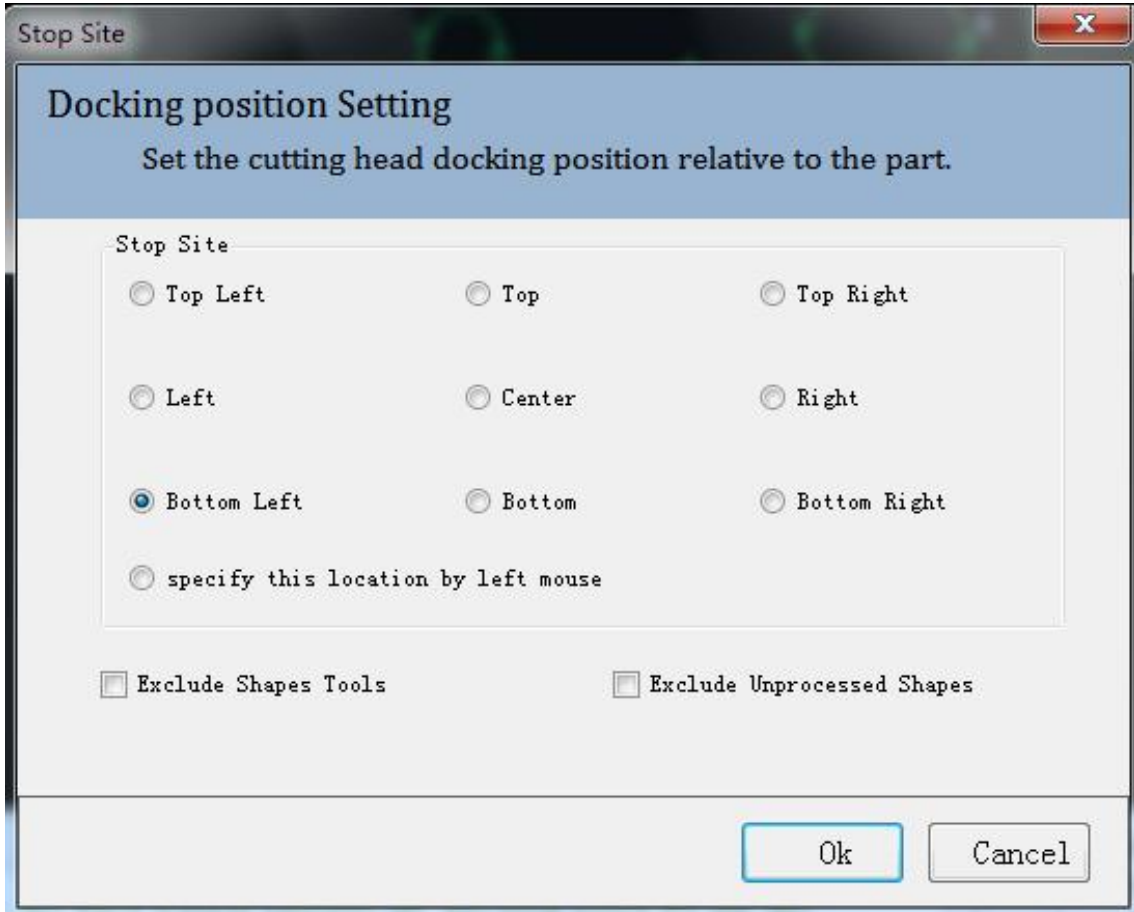

Note: "Select the zero reference by following the graphic" can be selected in the "Advanced Selection" in the Configuration Tool.

**2.1.10 Compensate**

By scaling the graphic, compensate the impact of the cutting slots to the parts. Sharp and round corner can be chosen in sharp point processing. Way of compensation includes Expand and contract, All expand, and All contract.

Select the graphic to be compensated and click on Compensate in Home sub-page. Set the parameters and click on OK to compensate the selected graphic, as shown below:

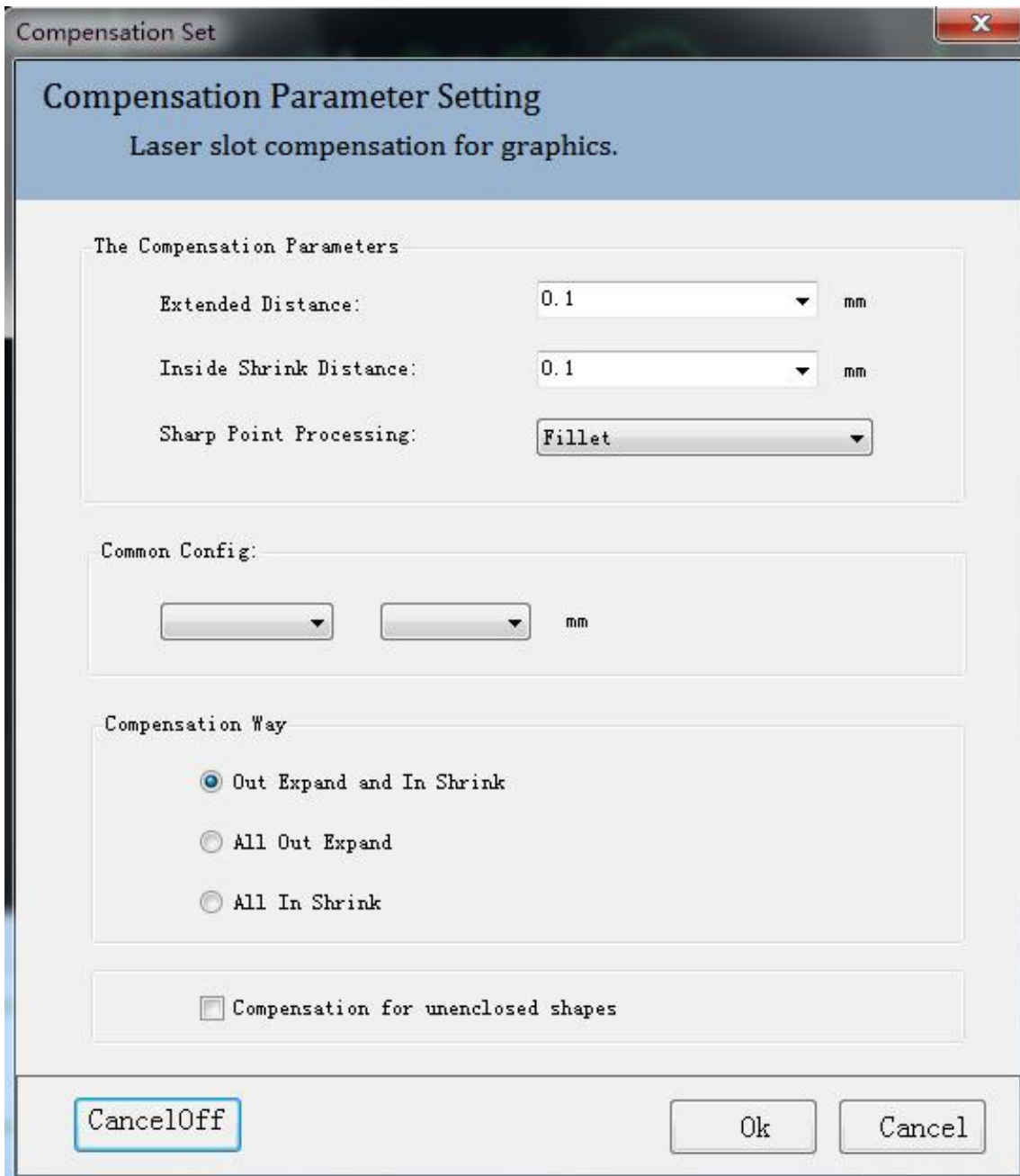

**(1) The Compensation Parameters**

- Extended Distance: the value that increases in equal intervals outwards.
- Inside Shrink Distance: the value that decreases in equal intervals inwards.
- Sharp Point Processing: to use sharp or filleted corner.

**(2) Common Config**

Read the configuration in the compensation library by selecting materials and thickness to quickly apply.  
 Modify default parameters in the compensation library by selecting materials and thickness.

**(3) Compensation Way:**

Way of compensation includes Out Expand and In Shrink, All Out Expand, and All In Shrink.

### 2.1.11 Outer Cut

Outer refers to cutting by adding a leadline outside the graphic contour.

Select the graphic with a leadline and click on Outer button to make the leadline being outside the contour, as shown below:

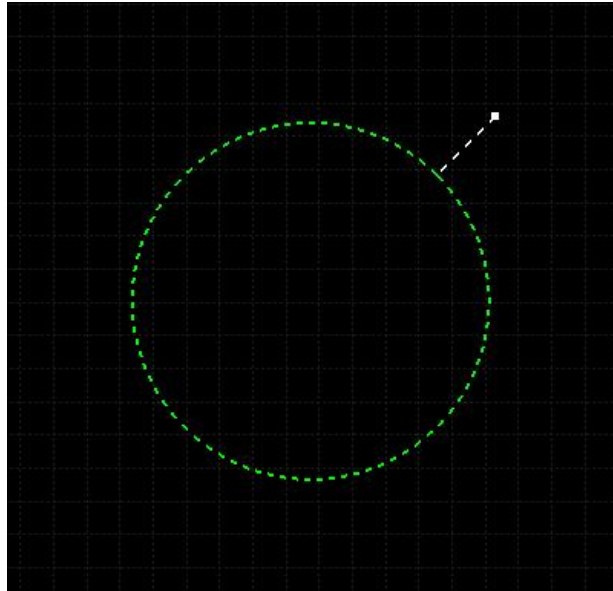

### 2.1.12 Inner Cut

Inner refers to cutting by adding a leadline inside the graphic contour.

Select the graphic with leadline and click on Inner button to make the leadline being outside the contour, as shown below:

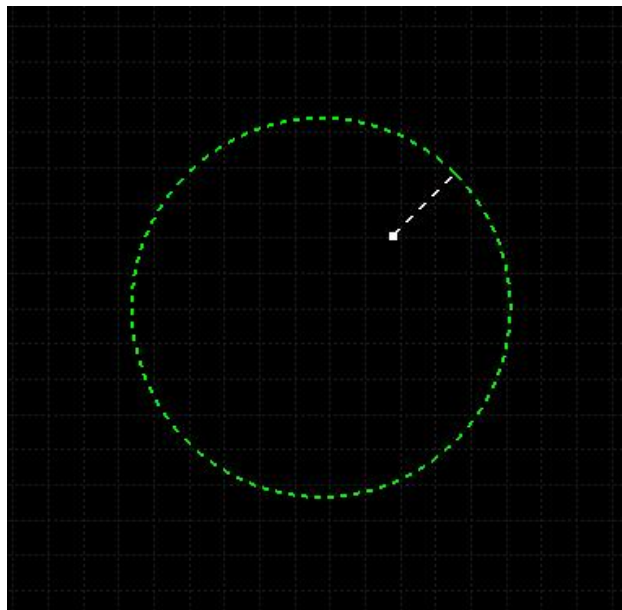



### 2.1.13 Ring Cut

Add Ring Cut or cooling point to the graphic.

Select the graphic to be ring cut and click on Ring Cut in Home sub-page. Set the parameter for ring cut and click on OK to complete, as shown below:

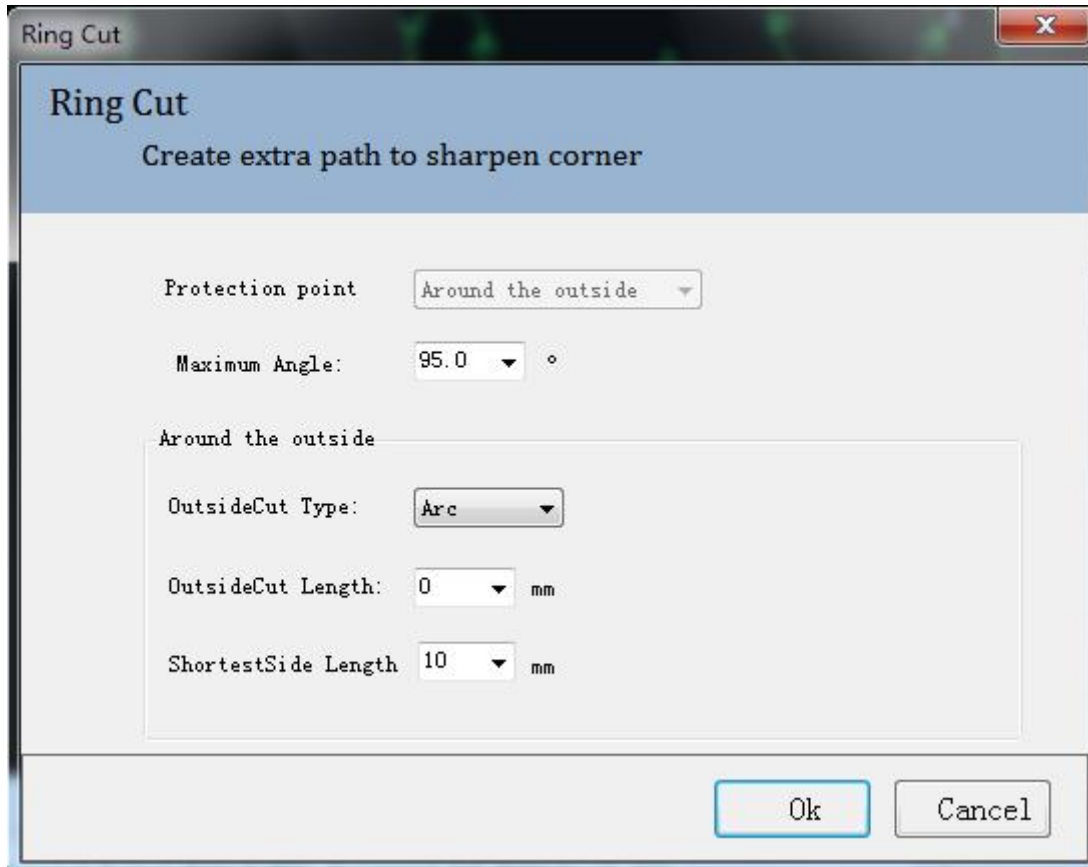

Protection Point: select the type of ring cut., with the option of around the outside.

Maximum Angle: corner bigger than this angle will not use the outside cutting.

OutsideCut Type: select the arc or triangle as the contour of outside cutting.

OutsideCut Length: set the perimeter of the contour of outside cutting.

ShortestSide Length: set the shortest edge length.

The graphic added with ring cut is shown on the left.

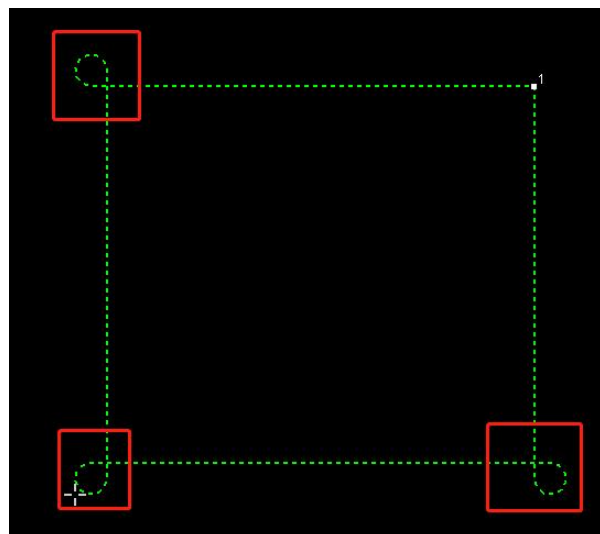

2.1.14 MicroJoint

The workpiece with micro connections can avoid falling off. Micro Joint includes manual and auto ones.

(1) Manual MicroJoint

Select the graphic to be micro connected and click on MicroJoint button in Home sub-page. Set the parameter for manual microjoint and click on OK. Then, click on the contour of graphic to complete. The setting of manual microjoint is shown as below:

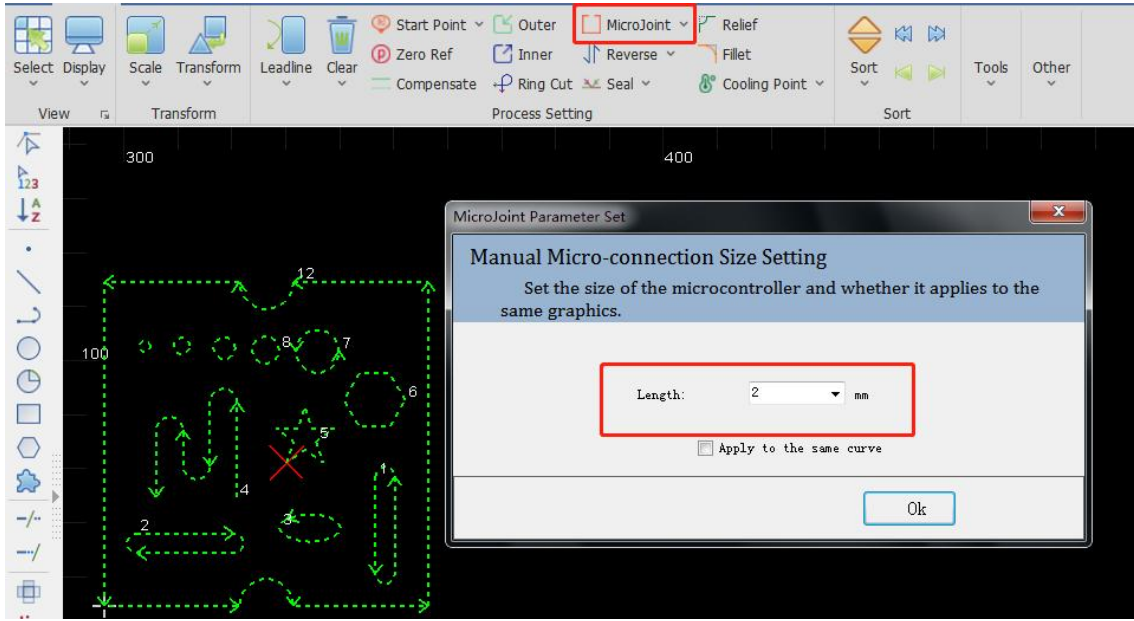

(2) Auto MicroJoint

Select the graphic needs to micro connect and click on the drop-down button on the right of the MicroJoint.

Click on Auto MicroJoint in the drop-down bar. Set the parameter of auto microjoint and click on OK to complete, as shown below:

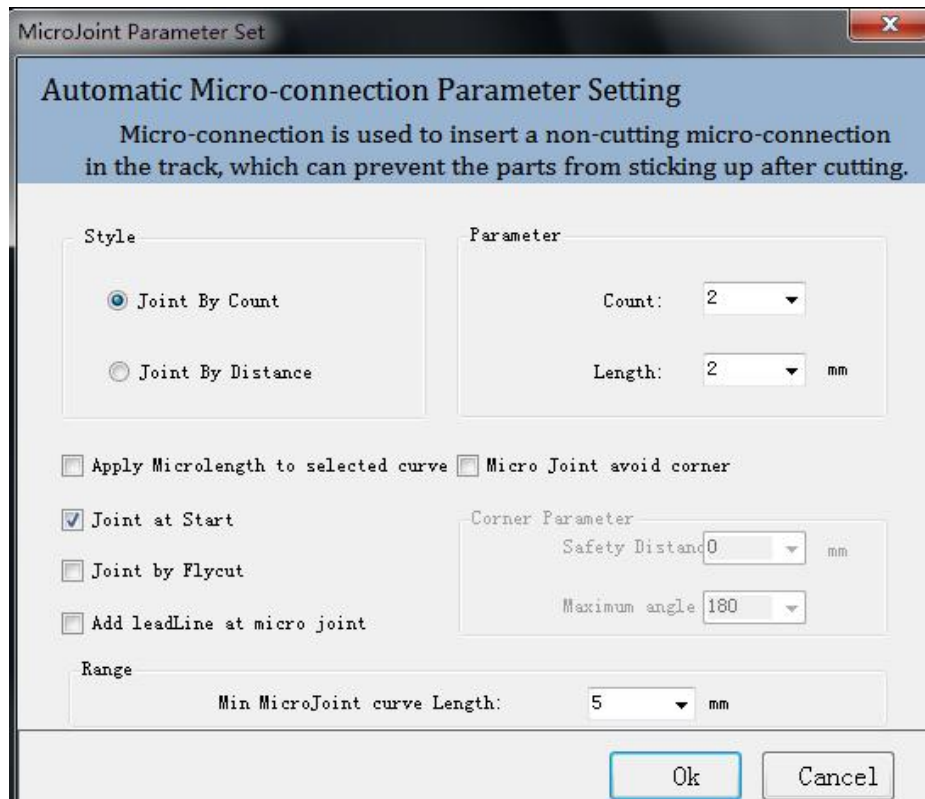

(1) Style

Joint by Count: the amount of micro connection in each contour.

Joint by Distance: the micro connection added by fixed distance.

(2) Parameter

Count: the amount of micro joint in each contour.

Length: the length of the micro joint.

### (3) Advanced Options

Apply MicroJoint to selected graphic: modify the micro joint size of the selected graphic and change all the selected graphics into the same size.

Joint at Start: select to add one micro joint at the start point.

Joint by Flycut: select to add one micro joint in fly cutting.

Add Leadline at micro joint: select to add a leadline at micro joint. Deselect, the leadline can only be added after exploding microjoint.

### (4) Corner Parameter

Micro Joint avoid corner: select to use the function.

Safety distance: the determination range of corners.

Maximum angle: the determination angle of corners.

Take the parameters in the figure above as an example: the corner whose angle is less than  $180^\circ$  will not be added the micro joint, including the distance near it for 5mm, though the corner fits the conditions.

### (5) Range

Min MicroJoint curve length: if the perimeter of the graphic is less than the minimum length, there will not add the micro joint.

### 2.1.15 Reverse

Adjust the processing direction.

**(1) Reverse:** if the processing direction now is clockwise, select the graphic and click on Reverse. Then, the selected graphic will be processed in an anticlockwise direction, as shown below:

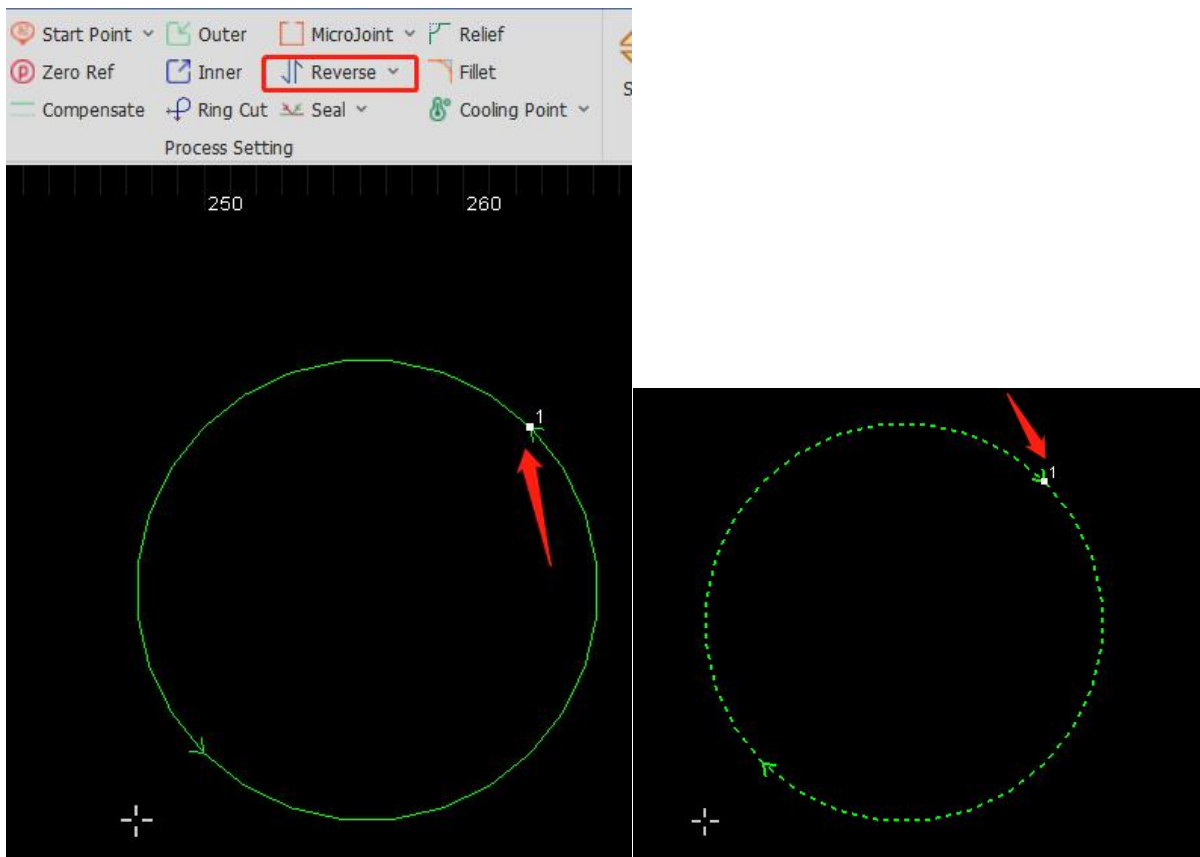

- (2) **CCW**: set the graphic to be processed in the anticlockwise direction.
- (3) **CW**: set the graphic to be processed in the clockwise direction.

**2.1.16 Over**

Set the overcut length for the selected contour.

Select the graphic to be overcut and click on Over button in the Home sub-page. Set the overcut length and click on OK to complete, as shown below:

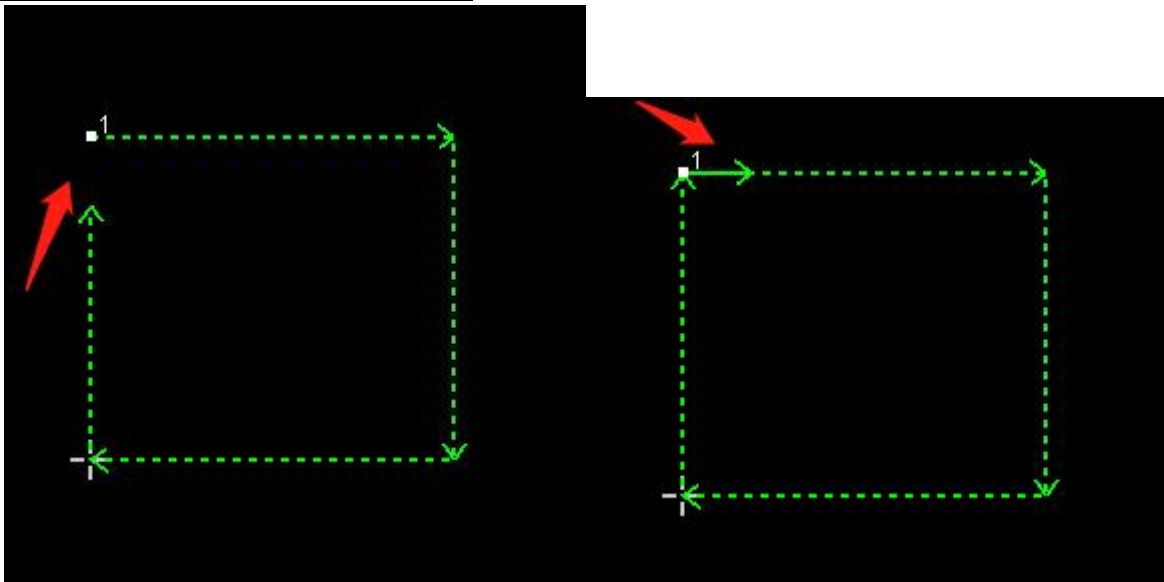
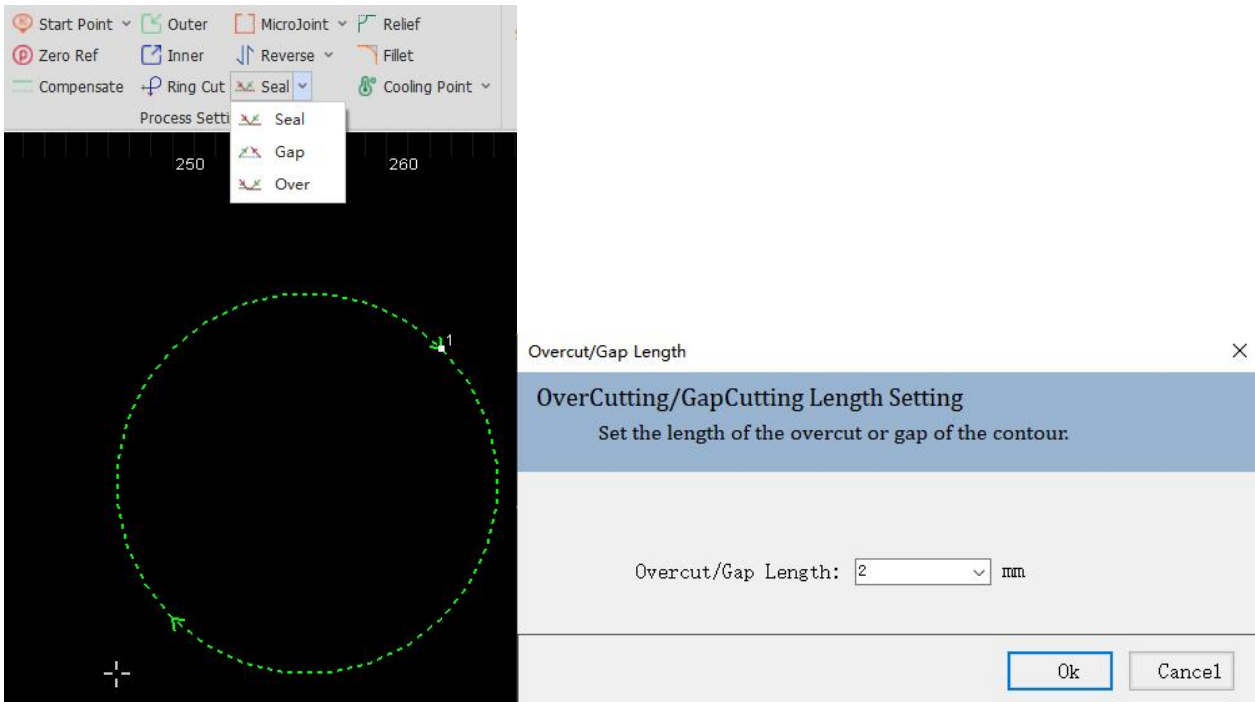

2.1.17 Relief

Click on  button to generate release corners for the following bending process.

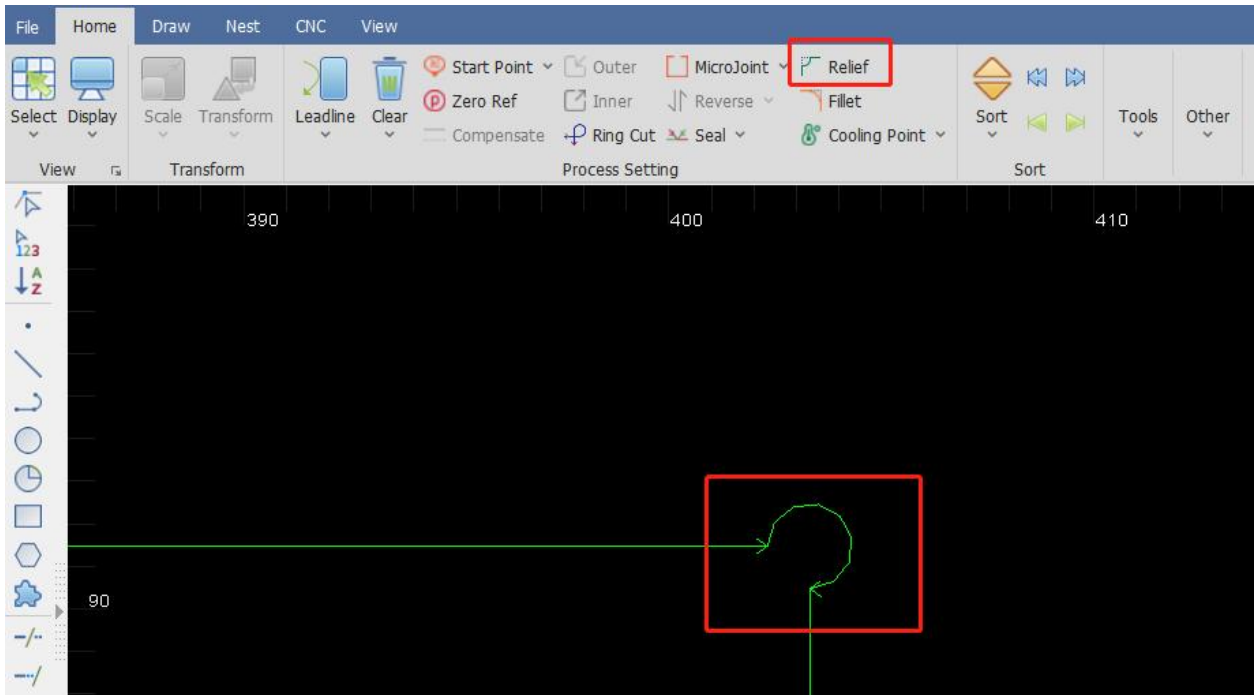

2.1.18 Fillet

Switch the sharp corners into the filleted corner.

Select the graphic needs fillet and click on Fillet button in the Home sub-page. Set the fillet radius and click on OK. Then, click on the corner of the graphic to complete. The setting of fillet is shown as below:

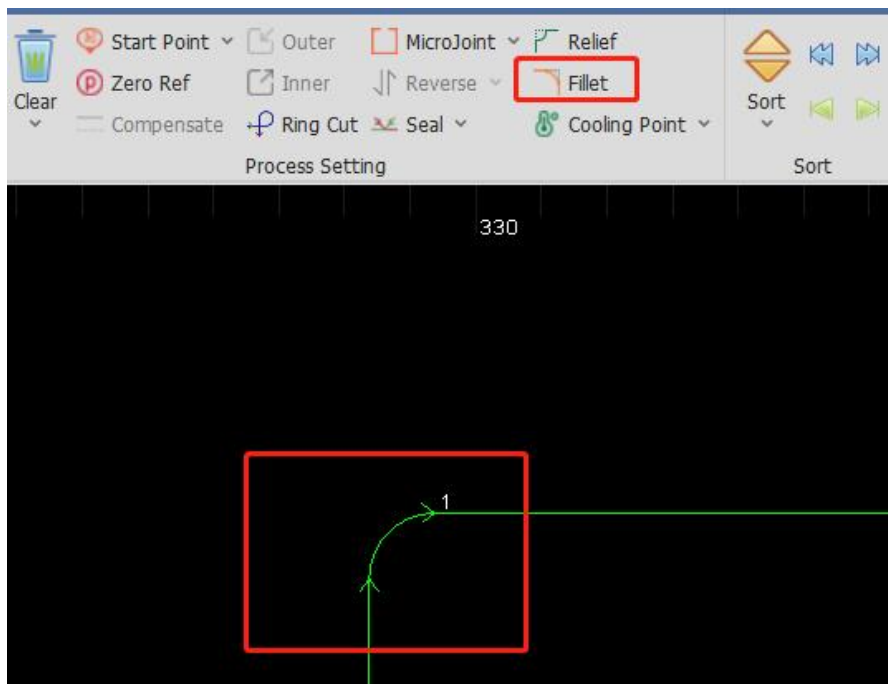

### 2.1.19 Cooling point

The cooling point is used to avoid the workpiece being incomplete for overheating. There are manual and auto cooling.

#### (1) Manual Cooling

Click on Cooling Point in the Home sub-page and select the contour of the graphic to complete, as shown below:

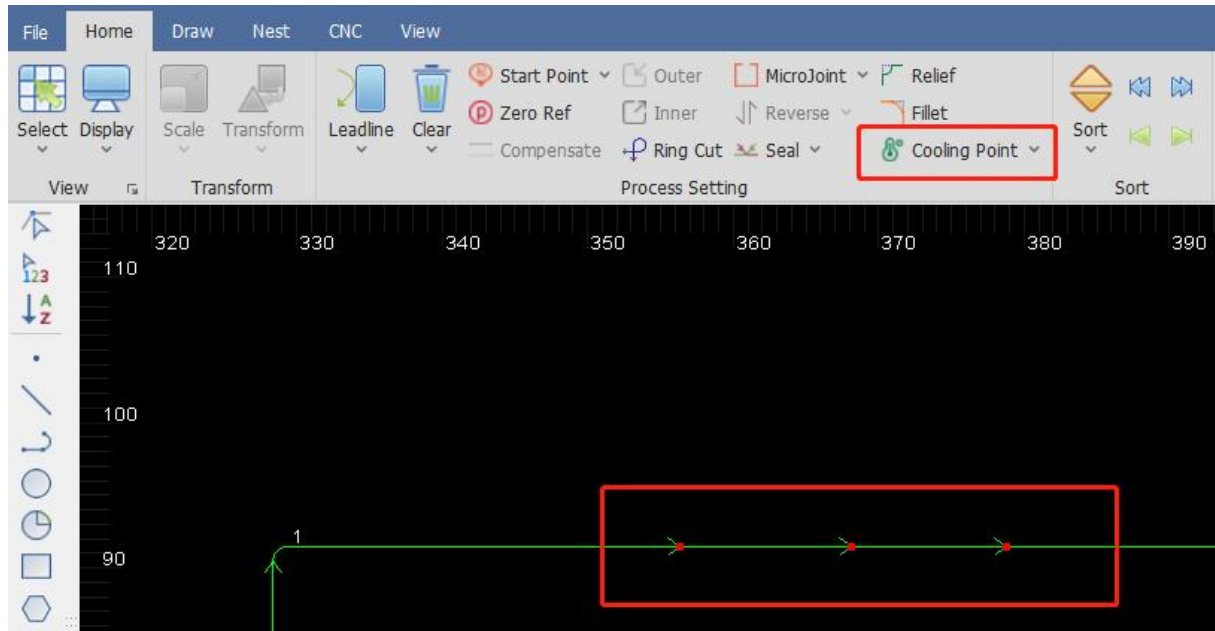

#### (2) Auto Cooling Point

Select the graphic that needs cooling point and click on the drop-down button on the right of Cooling Point.

Click on Auto Cooling Point in the pop-up drop-down bar.

Set the parameter of the cooling point and click on OK to complete, as shown below:

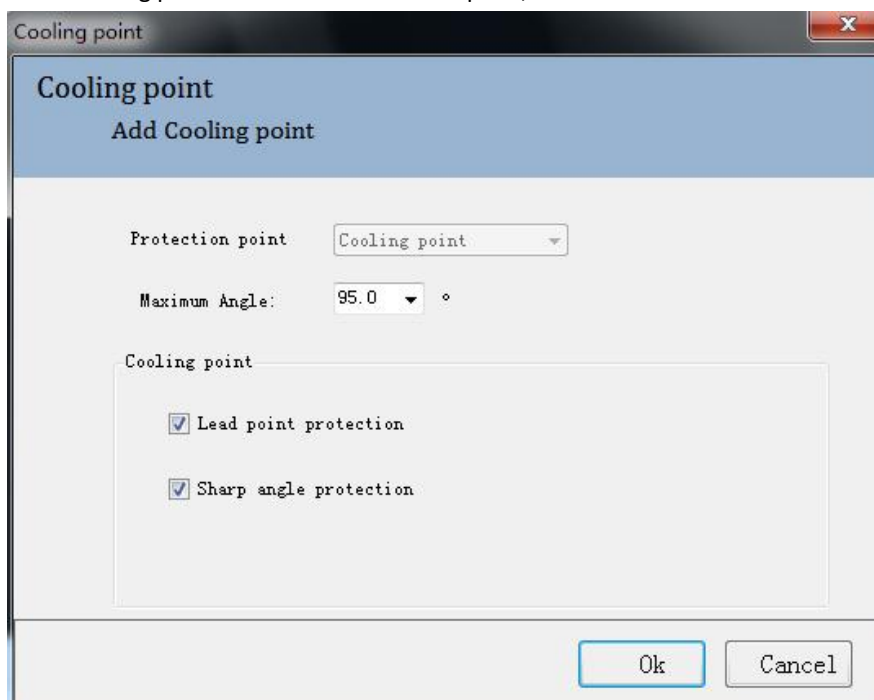

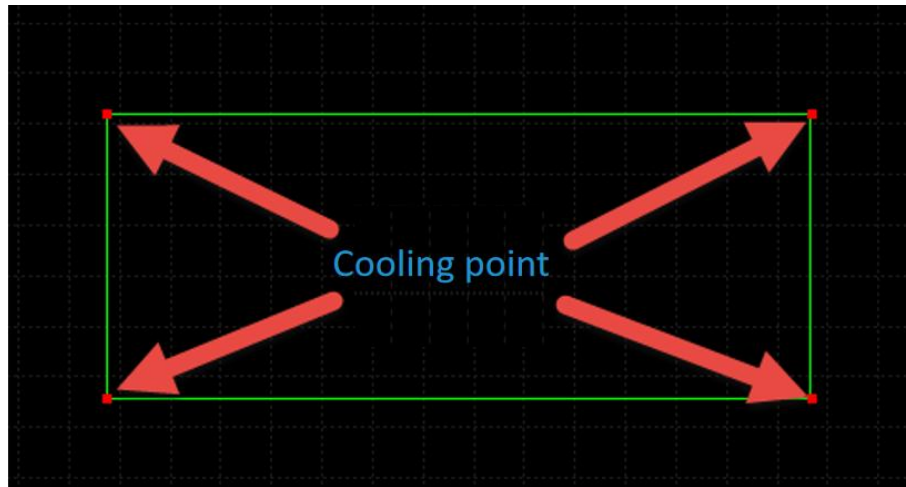

**Maximum angle:** corners bigger than this angle will not use the cooling point.

**Lead point protection:** select to add the cooling point at the start point of the graphic.

**Sharp angle protection:** deselect the function and not to add the cooling point at corners.

**Manual cooling point:** manually select a corner to add cooling point for the graphic.

Select the graphic and click on Clear Cooling Point in the drop-down bar beside the Cooling Point button to clear the cooling points in the graphic.

### 2.1.20 Sort

Sort the cutting sequence of graphics according to different rules.

Select the graphics that need to be sorted and click on Sort in the Home sub-page. The graphics will be auto sorted. Click on the drop-down button under Sort to see there are several ways to sort. Select the graphics and click on one way to sort. The graphics will be sorted in that way. Ways of sorting are shown below:

- ✓ Smart Sort
- Grid Pattern
- Local Shortest Path
- Layer Sort
- Smaller Vector Prior
- Left to Right
- Right to Left
- Top to Bottom
- Bottom to Top
- Arc Sort
- Manual Sort ▶

In the Sort column, four manual sorting buttons can adjust the graphics after auto-sorting, as shown below:



**Move Front:** select one graphic among graphics, and click on the button to make it move to the front.



**Move Last:** select one graphic among graphics, and click on the button to make it move to the last.



**Move Prior:** select one graphic among graphics, and click on the button to make it move forward.



**Move Next:** select one graphic among graphics, and click on the button to make it move backward.



## 2.1.21 Array

Quickly copy the graphics. There are two kinds of an array: rectangular and circular.

### (1) Rectangular

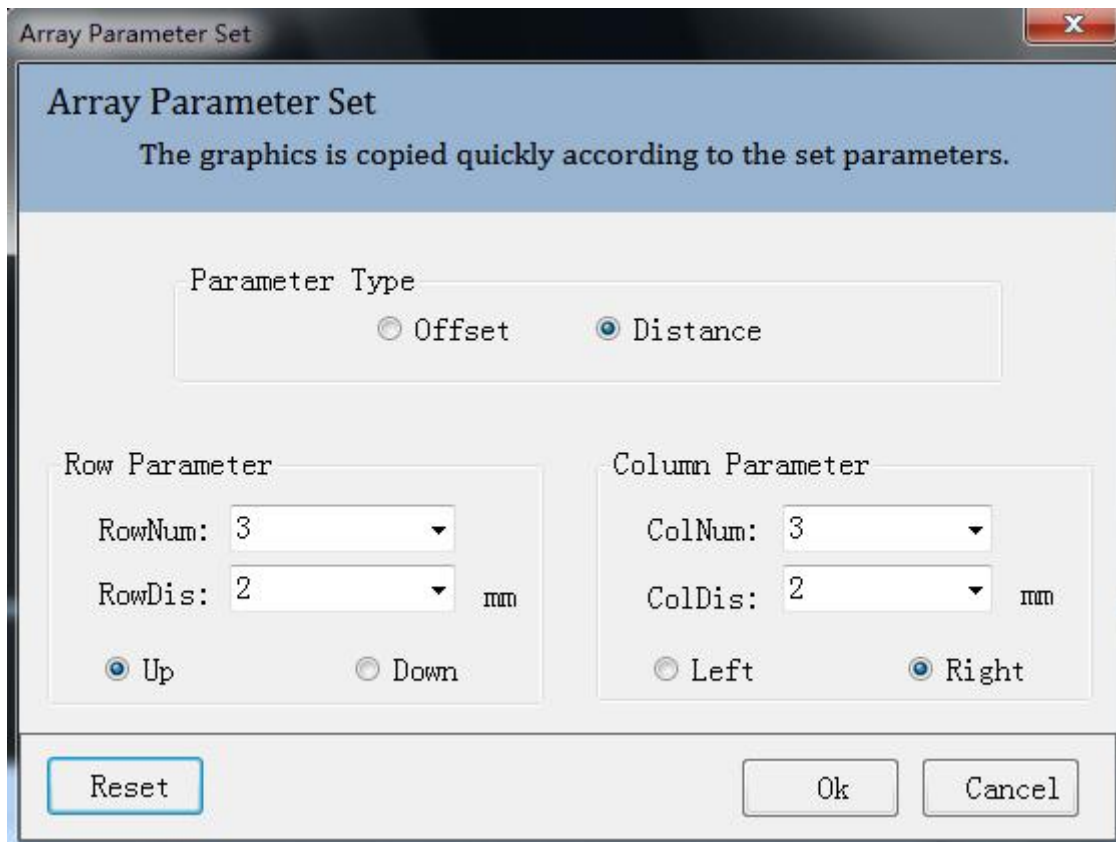

Select the graphic to be copied in an array and click on Array button in the Home sub-page.

Set parameters of the array and click on OK to complete. The parameter setting is shown as below:

- **Parameter type:** select to array according to offset or distance.
- **Row / Column Num:** the number of row and column in the array
- **(Row / Column) Distance / Offset:** the distance and offset value
- **Up / Down / Left / Right:** directions of the array

### (2) Circular

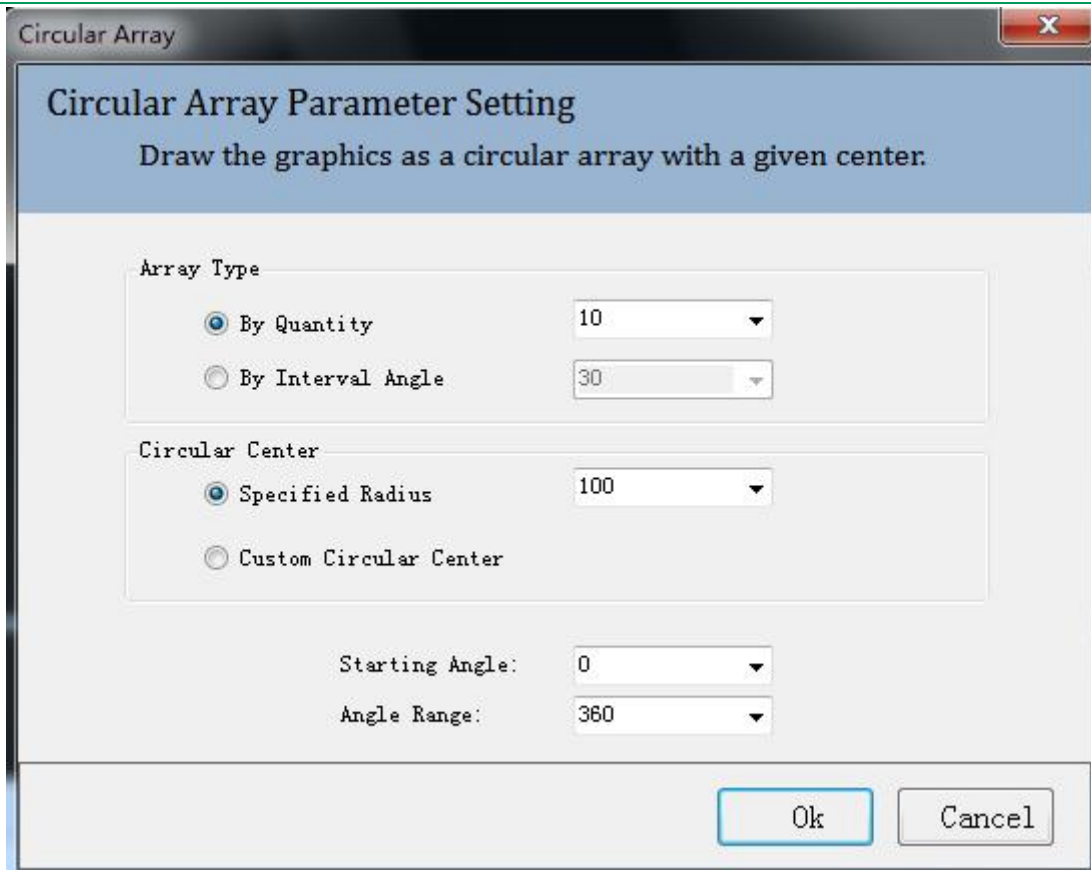

Select the graphic to be arrayed and click on the drop-down button under Array. Click on Polar in the drop-down bar. Set parameters of the array and click on OK to complete. The parameter setting is shown as below:

- **Array Type:** array by quantity or interval angle.
- **Circular Center:** set by specified radius or custom stretching in the drawing area.
- **Starting angle:** starting angle of the array.
- **Angle range:** array within the angle range.

**2.1.22 Group**

Grouping multiple graphics into a whole to avoid shifts in the position of dragging graphics.

Select multiple graphics and click on Group button in Home sub-page. The selected graphics will be a whole. The sorting and position of graphics and the layers will be fixed after being grouped. Then, the graphics will not change if sort or drag them. Click on the drop-down button of Group to see the drop-down bar, as shown below:

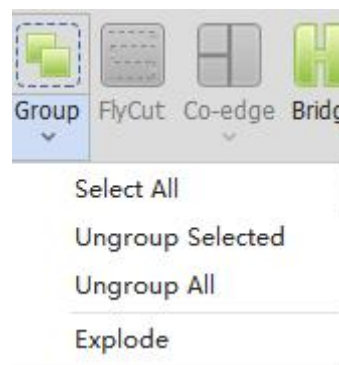

- **Select All:** select all groups in the current drawing.
- **Ungroup Selected:** select the group of graphics and click on Ungroup Selected button. The selected group will be canceled.
- **Ungroup All:** click on Ungroup All button and all groups in the current drawing will be canceled.
- **Explode:** select the graphic and click on Explode. The selected graphic will be broken up into the smallest segments of a line (arcs or lines).

### 2.1.23 Fly Cut

Set the selected graphics as the path and layer. The parameter setting is shown below:

**Fly Cut**

**Fly-cut Parameter Setting**

Set up a fast cutting process for the selected contour and plan the cutting path.

Fly Cut Mode: Linear FlyCut ▼

Sort Mode: Bottom to Top ▼

Starting Position Bottom Left ▼

Tolerance 0.3 ▼ mm

Max Smooth Joint 100 ▼ mm

Smooth Arc Radius 3 ▼ mm

Z-Axis not Lift Between Fly Groups

Laser leads length 0 ▼ mm

Laser Lags length 0 ▼ mm

Ok
Cancel

### (1) Fly Cut Mode:

Circle: select to cut in circular path.

Linear: select to cut in rectangular and polygon-shaped path.

Radar: linear cutting path without smooth arcs. Other cutting modes include Obround and Leadline.

**(2) Sort Mode:** select different sort modes to use different fly cutting paths.

**(3) Starting position:** select the start position of the graphic to be processed.

**(4) Tolerance:** if the horizontal and vertical length of the graphic is smaller than the tolerance, the graphic will be in a line or an array; if larger, the graphic will be in multiple lines or arrays.

**(5) Max Smooth Joint:** if the distance between two graphics is less than the max smooth joint length, an arc tangent will be auto-added to the cutting path to speed up processing and improve efficiency.

**(6) Smooth Arc Radius:** radius of the arc mentioned in Max Smooth Joint.

**(7) Z-axis not Lift Between Fly Groups:** select to lift the Z-axis in the travel between two groups in fly cutting.

**(8) Laser leads length:** laser on in advance for better cutting off the workpiece.

**(9) laser lags length:** as over-cutting distance, laser off delay is for better cutting off the workpiece.

### 2.1.24 Co-edge

Combine workpieces with common edges to use one edge for cost efficiency and improve processing efficiency.

Select graphics to be co-edged and click on Co-edge button in the Home sub-page. Co-edge parameter setting pops up by which you can select T-type or common co-edge, and the way to sort. Click on OK to complete. After co-edging, the graphics will be grouped into one contour to avoid sorting errors. The result of co-edge is shown below:

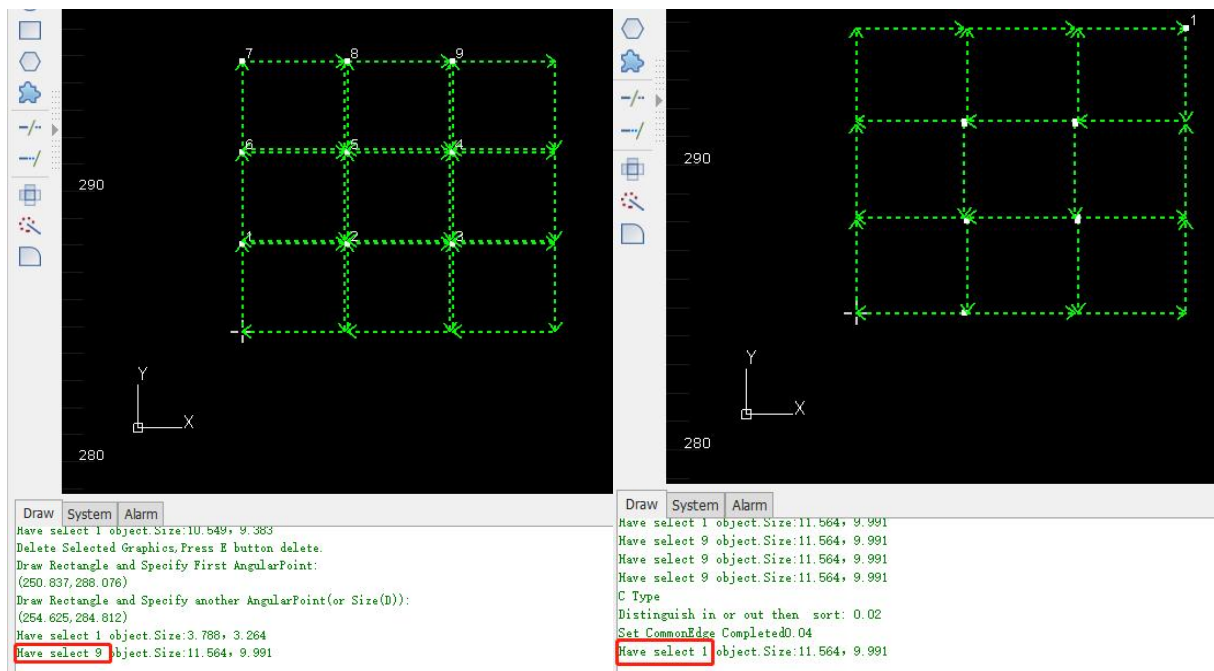

2.1.25 Bridge

After setting the maximum distance of the adjacent curves to be bridged and the bridge width, add the bridge for selected contours.

Select the graphic to be bridged and click on Bridge button in the Home sub-page. According to prompts in the log, double-click the drawing area to see the bridge line. The parameter setting pops up. After setting, click on OK to complete.

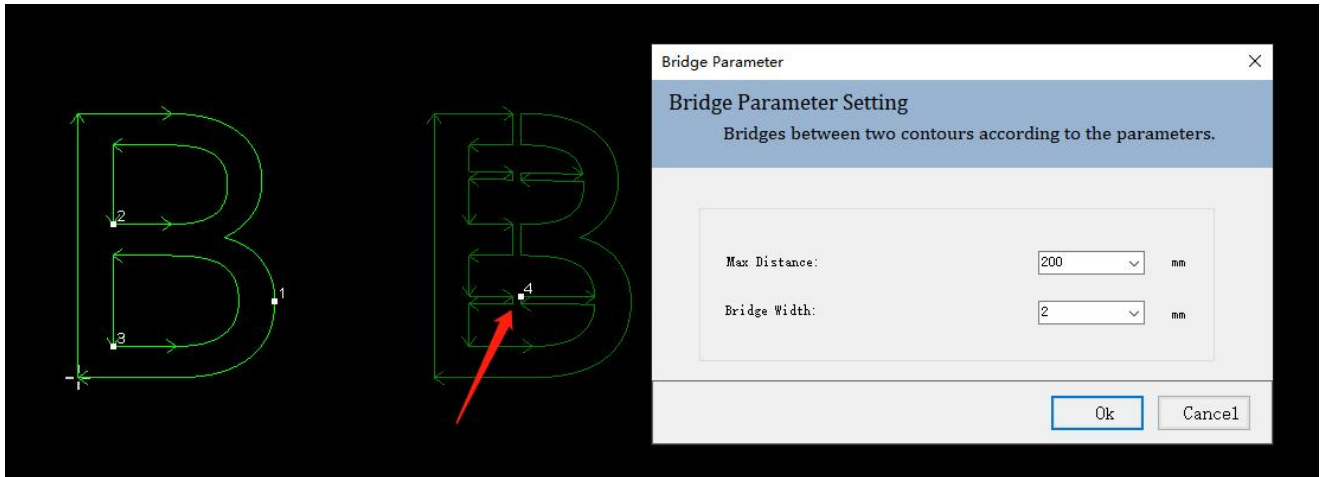

Bridge Parameter:

- **Maximum distance** between bridging adjacent curves: add bridges to curves on the bridging path that are less than this distance.
- **Bridge width**: the width of the bridge.

2.1.26 Measure

Measure the distance between two points.

Click on Measure button in the Home sub-page. According to prompts in the log, click on the start and end points in drawing area. The measuring result will display in the log of drawing, as shown below:

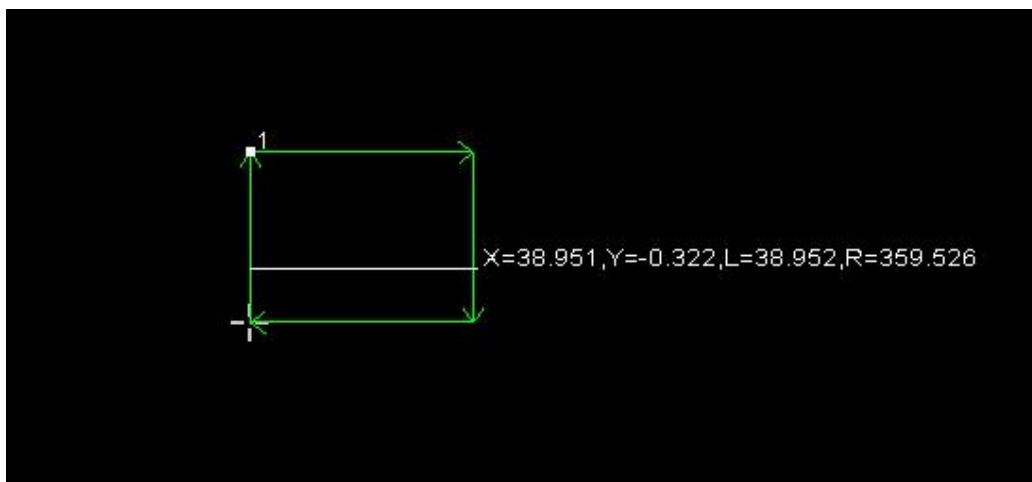

## 2.1.27 Optimize

Optimize the graphics.

Click on Optimize button in the Home sub-page, and the drop-down bar will pop up with selections as shown below:

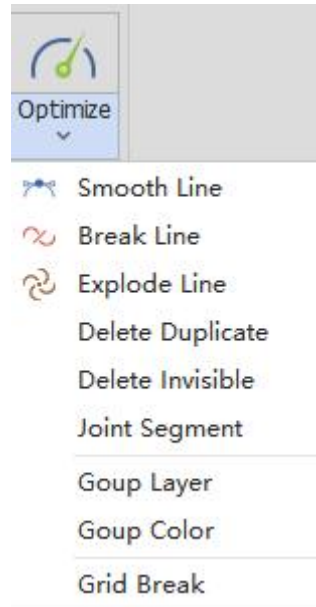

**(1) Smooth Line:** select multiple lines to be optimized and click on Smooth Line. Then set the precision and click on OK to complete. The graphics will be auto-optimized, as shown below:

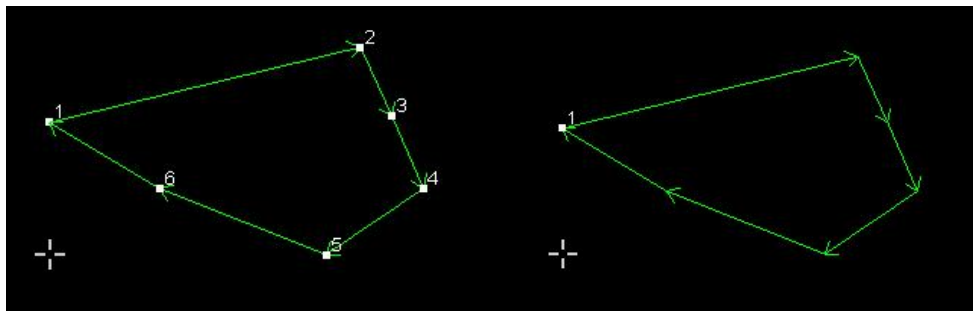

**(2) Break Line:** click on Break Line and then click on the point on the graphic contour to break it. The process can be continuous and can be canceled by pressing the ESC button, as shown below:

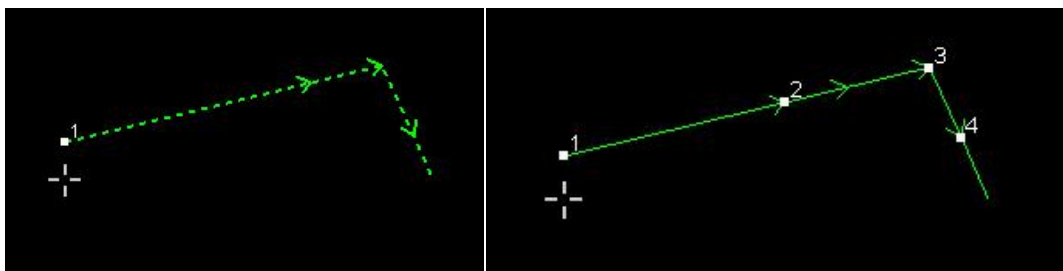

**(3) Delete Duplicate:** some lines are duplicates though visually not. Select the graphic, click on Delete Duplicate, and set the deletion tolerance. If the max distance of two contours are less than the tolerance, they are duplicate. After parameter setting, click on OK to complete, as shown below:

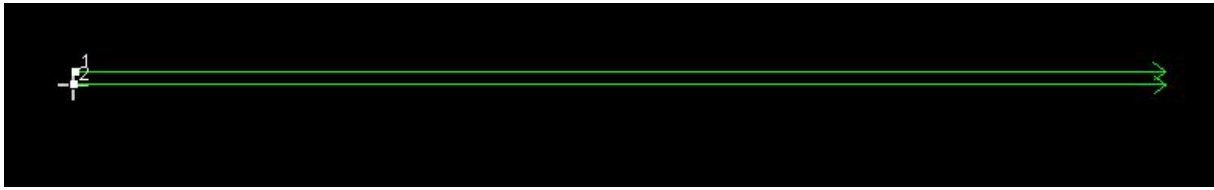

**(4) Delete Invisible:** In the imported graphics, there may be some graphics whose size is too tiny to recognize and the position may move in processing. You can click on Delete Invisible button to set the minimum contour size and click on OK to delete the tiny graphics whose size is smaller than the minimum one.

**(5) Joint Segment:** in drawing area, there may be some graphics are connected visually but actually not. Click on Joint Segment button and set the MerTolerance, merging tolerance which refers to if the interval of the nearest breakpoints of two contours is within the tolerance, the contours will be joined together. After tolerance setting, click on OK to complete, as shown below:

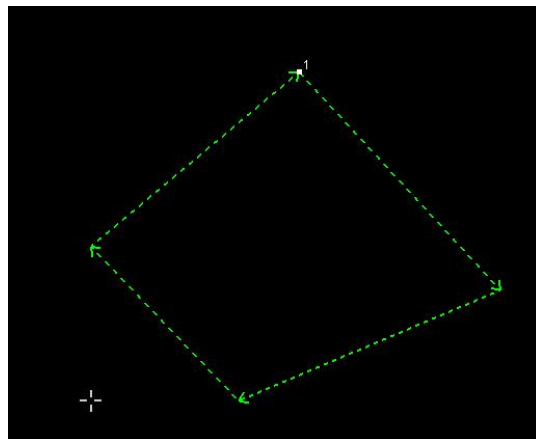
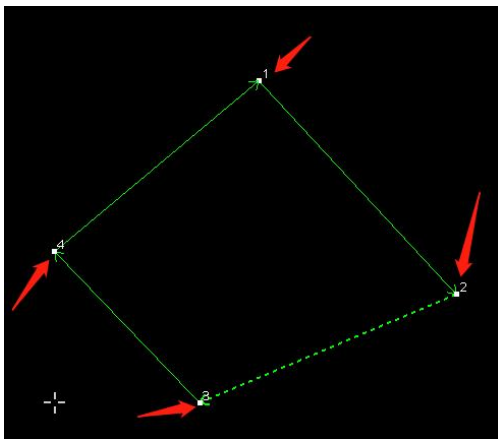

## 2.2 Draw

When drawing a graphic in the drawing area, there will be a prompt of next step in the log area.

User can complete the drawing with the prompt.

### 2.2.1 Line

Click on Line button in the Draw sub-page and click on the start point and next point in the drawing area with the prompt in log to complete the drawing of a line.

Multiple lines can be drawn by continuously click on the next points. The end point of the line will be the start point of the next one. Press Enter to complete the drawing.

### 2.2.2 Rectangle

Click on Rectangle button in the Draw sub-page and click in the drawing area to set the first corner. Click on another point to set the other corner and complete the rectangle.

Click on the drop-down button under Rectangle button to get a drop-down bar which includes Rectangle, RoundRect, and Obround. Click on RoundRect or Obround by the the prompt in log to draw the needed graphic.

The drawing can also be done by input a fixed size. Left-click in the drawing area to set the first corner. Then press D on the keyboard and input the value of width and height with commas between them for separation. At last, press Enter to complete the drawing. For example, "D50, 100" means 50 wide and 100 high.

### 2.2.3 Circle

Click on the drop-down button under Circle button in the Draw sub-page to see the drop-down bar which includes Circle, 3-Point Arc, Scan Arc, and Ellipse.

- **Circle:** click on Circle button and left-click in the drawing area to set the center. Then, input the radius by the keyboard. At last, press Enter to complete.
- **3-Point Arc:** click on 3-Point Arc button. Click on three different points in the drawing area to complete the drawing.
- **Scan Arc:** click on Scan Arc button and click in the drawing area to set the center. Then, click on another point to set the radius and drag to set the arc size.
- **Ellipse:** click on Ellipse button and click in the drawing area to set the center. Then, click on one point to set the vertex of the short axis and another point to set the vertex of the long axis to complete drawing the ellipse.

It is suggested to use the Circle for drawing the graphics.

### 2.2.4 Polyline

Click on the drop-down button under Polyline button in Draw sub-page to see the drop-down bar which includes Polyline, Polygon, and Star for drawing.



• **Polyline**: click on Polyline button and click in the drawing area to set the start point. Drag the mouse and click again, and then repeat to draw graphics with multiple lines.

The default is to draw a straight line. You can switch it to an arc by pressing A on the keyboard, switch back to a straight line by L, and make the contour closed according to the selected line type by pressing C. Press Enter to complete the drawing.

• **Polygon**: click on Polygon button to set the number of edges and choose to be inner or outer tangent to the circle. Click on OK in the setting interface. Click on one point in the drawing area to set the center and drag the mouse to click on another point for setting the radius of the polygon.

• **Star**: there are two ways to draw a star-shaped graphic.

(1) Input the number of fixed points, the distance between the vertex and center, the side length, and the rotation angle. The star-shaped graphic will be auto-drawn by clicking on a point in the drawing area to set the star center.

(2) Input the number of vertices (fixed-point) and no other information. Set the center, inner vertex, and out vertex in the drawing area. Draw the star-shaped graphic by the three points. Its angle can be rotated randomly, as shown below:

The screenshot shows a dialog box titled "Star" with a close button (X) in the top right corner. The main title is "Star" and the subtitle is "Draw star parameter Settings". The dialog contains four input fields, each with a dropdown arrow on the right:

- Fixed-point number: 5
- The distance between the: 100 mm
- Star side length: 72.5 mm
- Rotation Angle: 0 °

At the bottom right, there are two buttons: "Ok" and "Cancel".

### 2.2.5 Point

Click on Point button in the Draw sub-page and click in the drawing area to complete drawing a point.

### 2.2.6 Text

Click on Text button in the Draw sub-page. Set the font and its size, input the text, and select to use Outline Font (Normal) or Single Line. After setting the parameter, click on OK and then click in the drawing area to complete the text insert.

### 2.2.7 Clip

Click on Clip button in the Draw sub-page. Then click on the graphic contour in the drawing area, and part of the contour will be deleted.

### 2.2.8 Extend

Click on Extend button and click on the line in the drawing area. The line will extend till it intersects with another graphic contour.

### 2.2.9 Group

The operation of this function is the same as the Group in the Home sub-page. For more details, please refer to 2.1.22.

### 2.2.10 Align and Sort

The operation of this function is the same as the Sort in the Home sub-page. For more details, please refer to 2.1.20.

There are multiple ways to Align and Sort in the Draw sub-page. Select the graphics to be aligned and click on one of them to align the selected graphics. Buttons to quickly align are shown as follows:



### 2.2.11 Optimize

The operation of this function is the same as the Optimize in the Home sub-page. For more details, please refer to 2.1.27.

### 2.3 Nest

AX3000 has equipped the function of auto-nesting. This section will describe the function in detail, so users can better use the software and improve processing efficiency.

Select the Nest sub-page and import or draw a graphic. The following rectangle is drawn as an example:

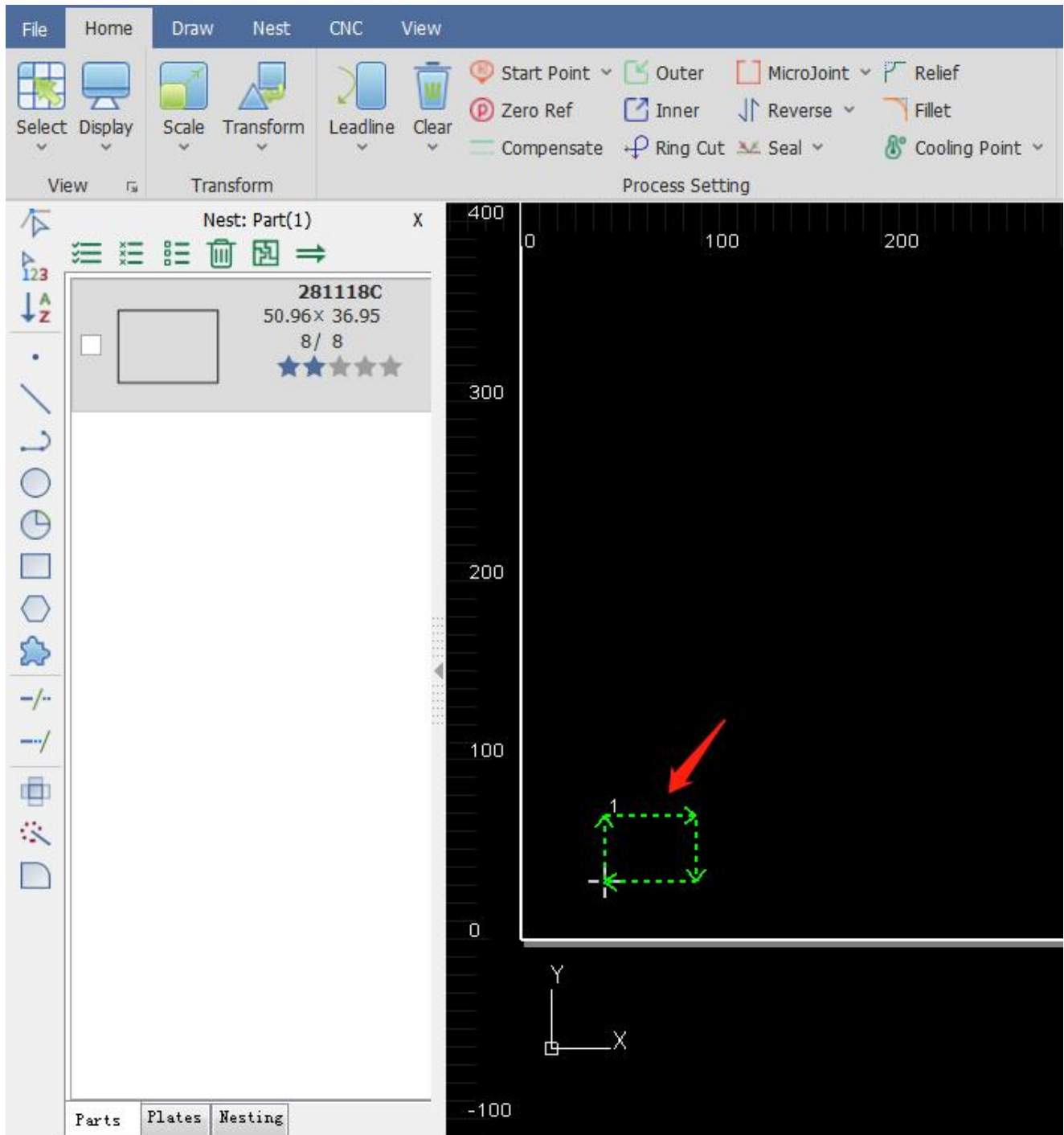

2.3.1 Part

Before nesting, turn the graphics into parts for cutting. A part consists of its inner and outer contours, and the outer contour is not a must. Add parts by selecting the graphics and right-clicking to add them to the parts list or by right-clicking in the left sidebar to import parts.

Set the selected graphic as a part: right-click in the drawing area and select Add to Part List, Input Count. In the pop-up interface, set the part quantity and its internal sorting method. If select to group selected shapes into one part, all the selected graphics will be a part.

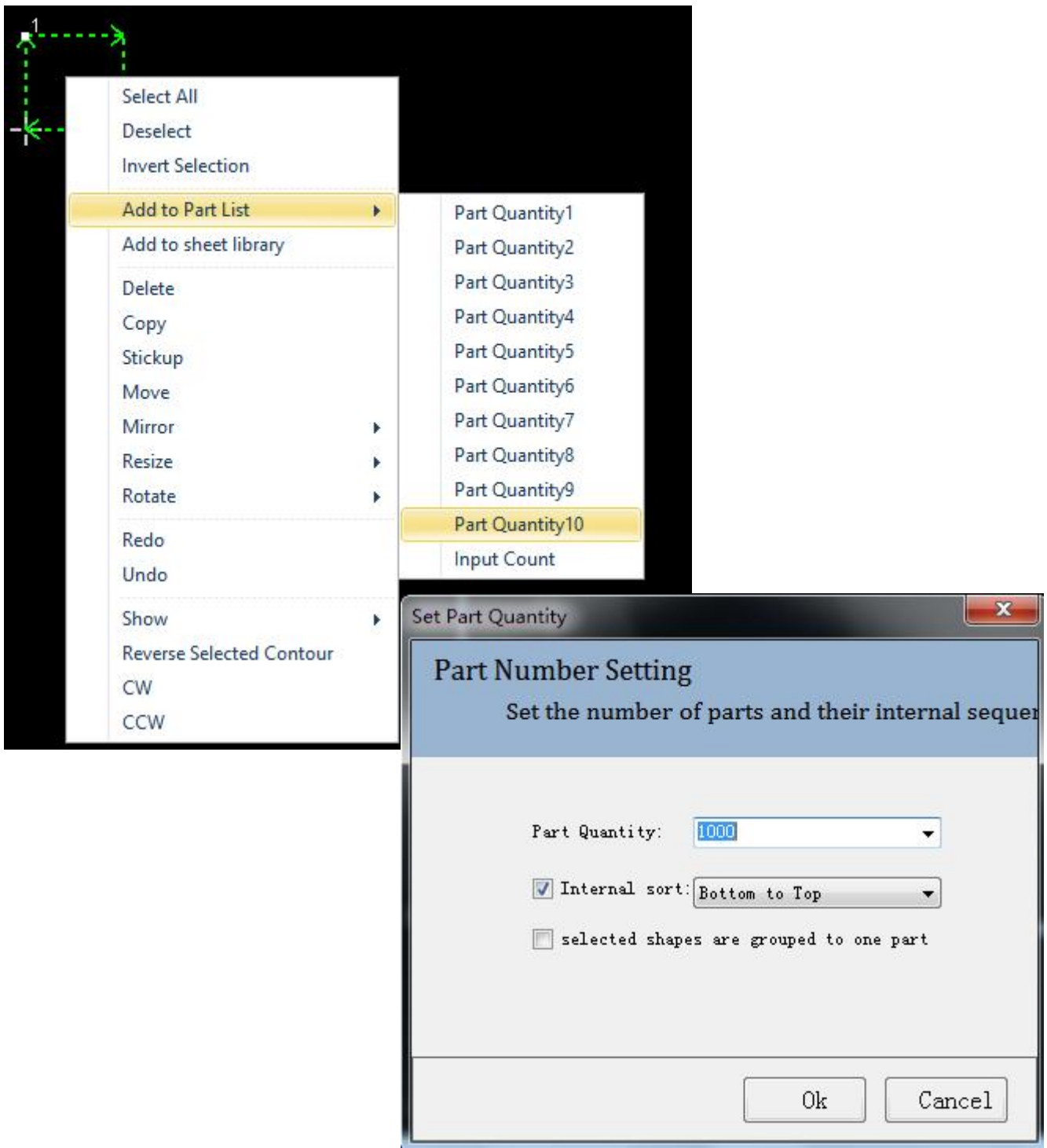

## 2.3.2 Nesting

With parts in the drawing area, there will be a left sidebar for nesting. You can set parts and plates in the sidebar.

- (1) **Quick Access Toolbar:** quickly select, delete and nest parts and plates.
- (2) **Part Bar:** display all the added parts.



### 2.3.3 Nesting Parameter

Set the nesting parameters.

- (1) **Board Set:** set the size and count of plates
- (2) **Set Parameter:** set the space between parts and interval between the part and the sheet margin (board edge).
- (3) **Auto Sorting:** set the sorting way and the nesting direction of the parts.
- (4) **Part Parameter:** select the parts to nest.
- (5) **Clear the previous nesting results:** whether to continue the nesting on the former results.
- (6) **Advanced:** click to set the advanced parameters.

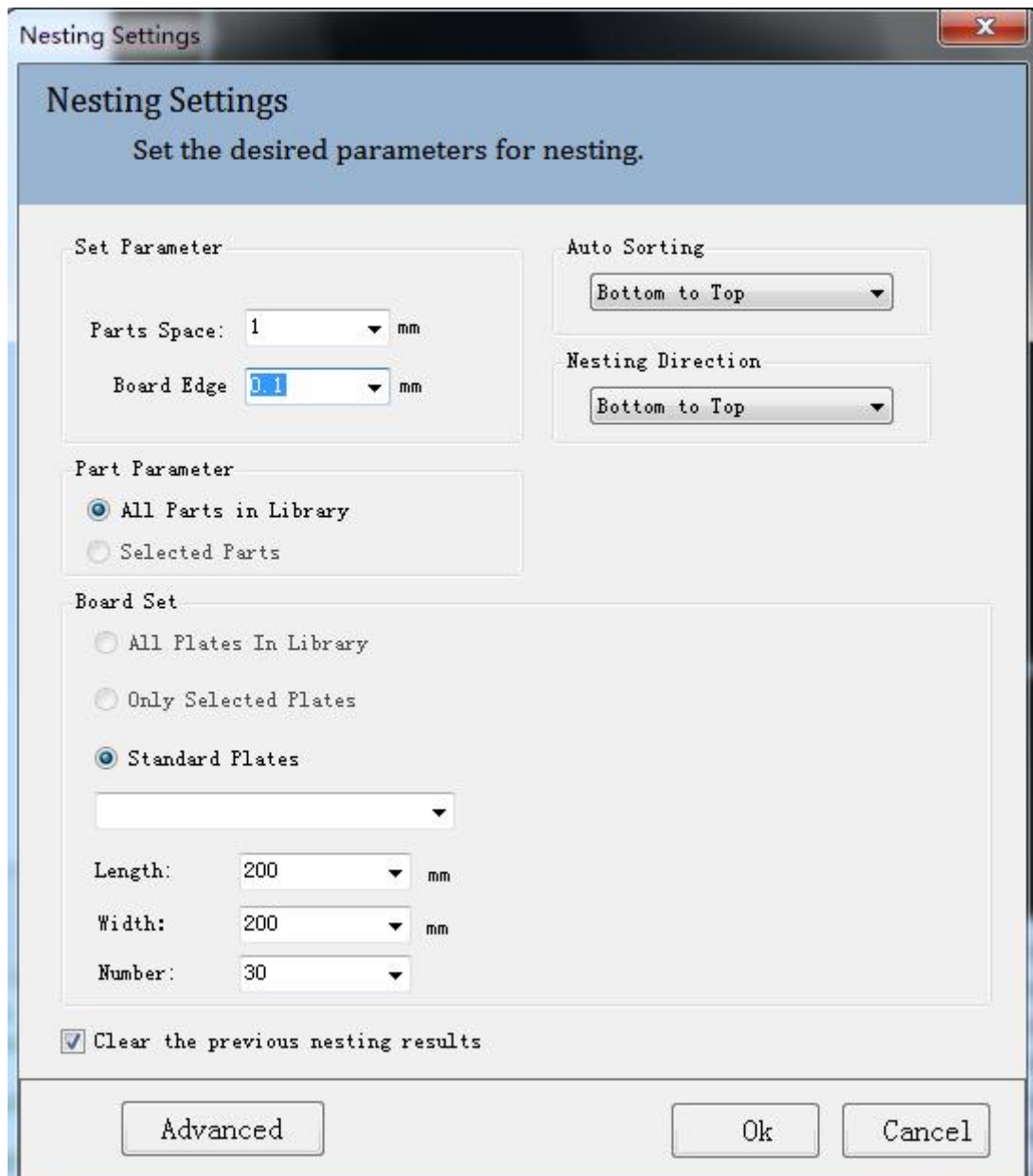

## 2.3.4 Advanced Parameter

- a. **Starting**: set the start point of nesting.
- b. **Nesting Dir**: set the priority of nesting direction.
- c. **Rotation Angle**: refers to the angle of each placement when placing the part (the smaller the angle, the better the result and the slower the nesting speed).
- d. **Nesting**: refers to the precision of nesting. The smaller the the value, the better the effect and the slower the speed.
- e. **Inside the hole**: decide whether to place the part in the hole of the waste area of another part. Select to improve the utilization of the plate with slower nesting speed.
- f. **Considering incoming**: decide whether the edges of the part have leadlines.
- g. **Automatic combination**: combine the placed nesting parts and copy the resulting nesting to speed up nesting.
- h. **Mirror image**: allow the mirroring of the graphic to improve the utilization of the plate.
- i. **Merge common**: turn on the function and complete the nesting on co-edged parts.
- j. **AutoNEST strategy**: select grid to sort the parts in rows and select compact to sort into any space.

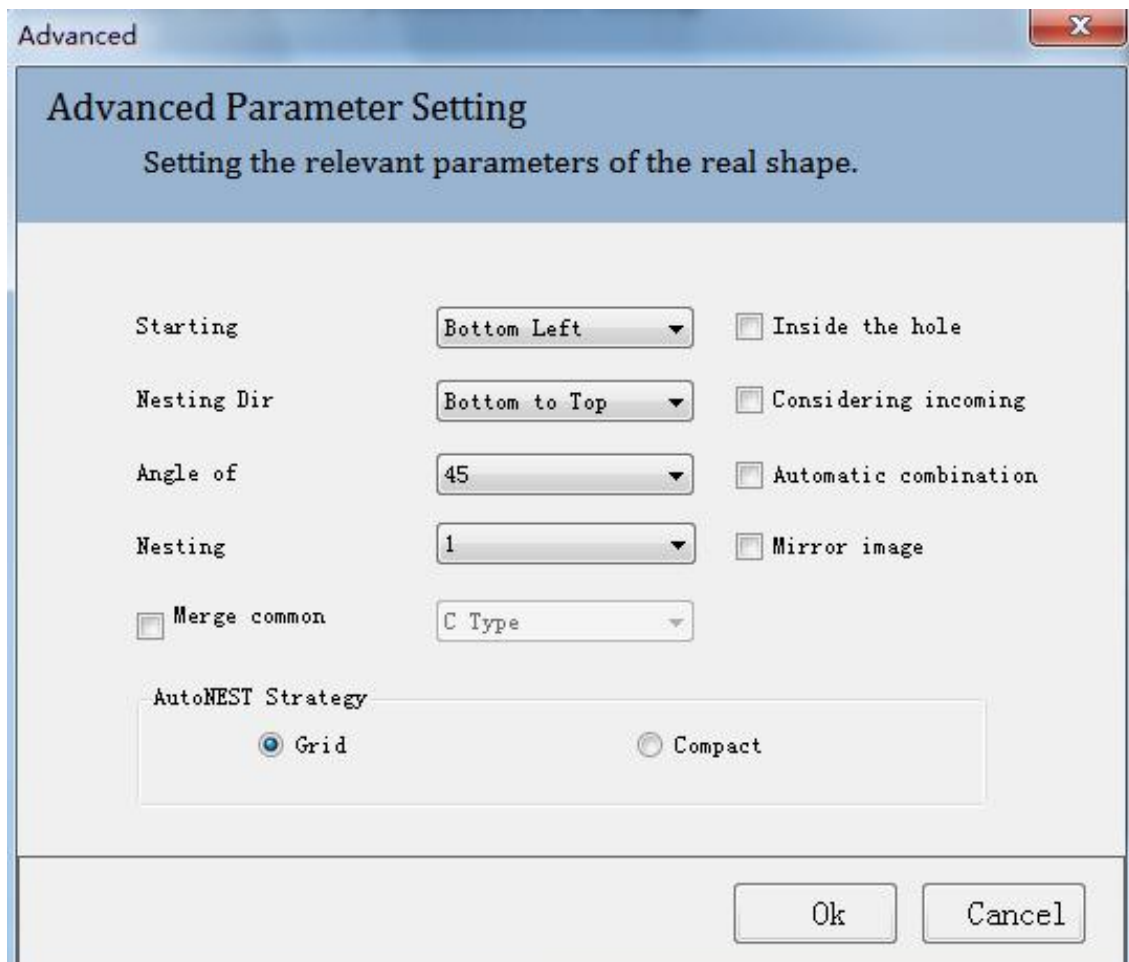

## 2.3.5 Plate

Right-click to select different ways to delete.

**Delete:** delete current selected graphic.

**Delete Selected Results:** delete current selected graphics.

**Delete All Results:** after deleting all the plates in the plate list, progress as normal.

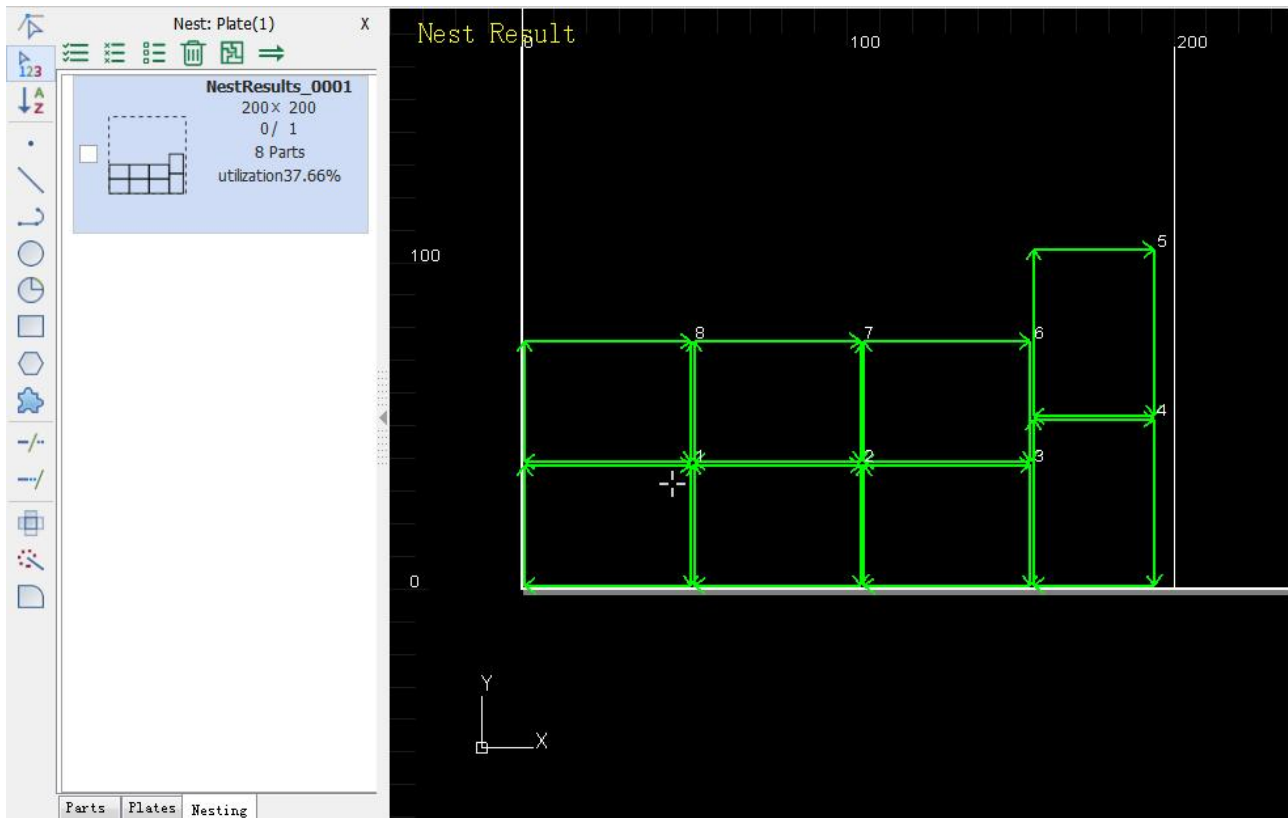



### 3 Process Parameter

Click on Process button in the toolbar. The interface for setting process parameters will pop up. It includes most of the process parameters in cutting. There are 8 layers, 7 process layers, and 1 for the graphic not to be processed. Parameters for every layer are separate.

#### 3.1 Process Parameter Setting



- (6) Tree-like Process Structure
- (7) Layer
- (8) Mode
- (9) Cutting
- (10) Other Parameters
- (11) Power Curve
- (1) Cutting, Piercing, and Advanced Parameter
- (2) Remark
- (3) Import and Export
- (4) Material Configuration
- (5) OK, Cancel, and Apply

There is a tree-like structure to save the process. All the cutting parameters can be added to the structure on the left for users to view and use.

Right-click on any material in the process structure to add a new material or thickness type. Users can add a new type of material or the thickness of material in the interface popped up.

Take adding BR in the following figure as an example:

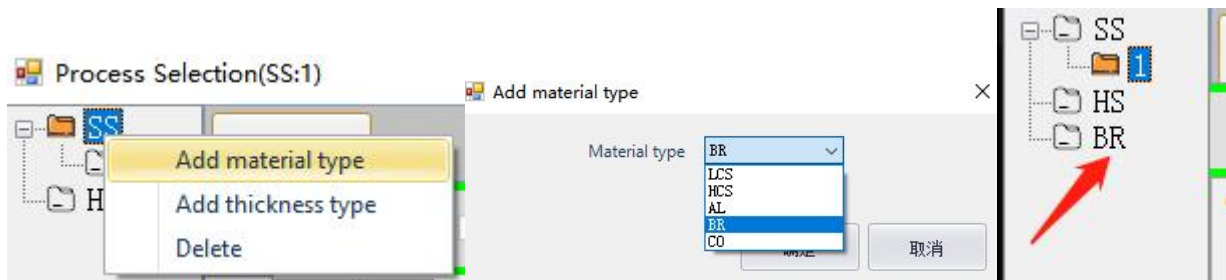

After adding BR, add its thickness by right-clicking on the material, BR.

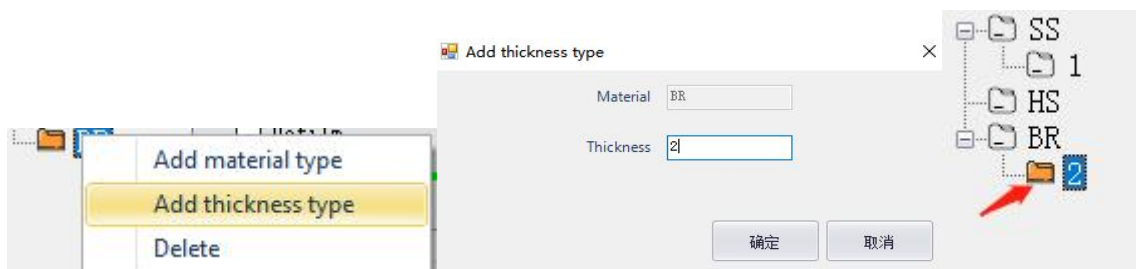

### 3.2 Tree-like Process Structure

### 3.3 Layer

There are 7 process layers and every one of them can be set separately.

Select the graphic in the drawing area and click on the corresponding layer button on the right. And the graphic will be processed using the selected layer process, as shown below:

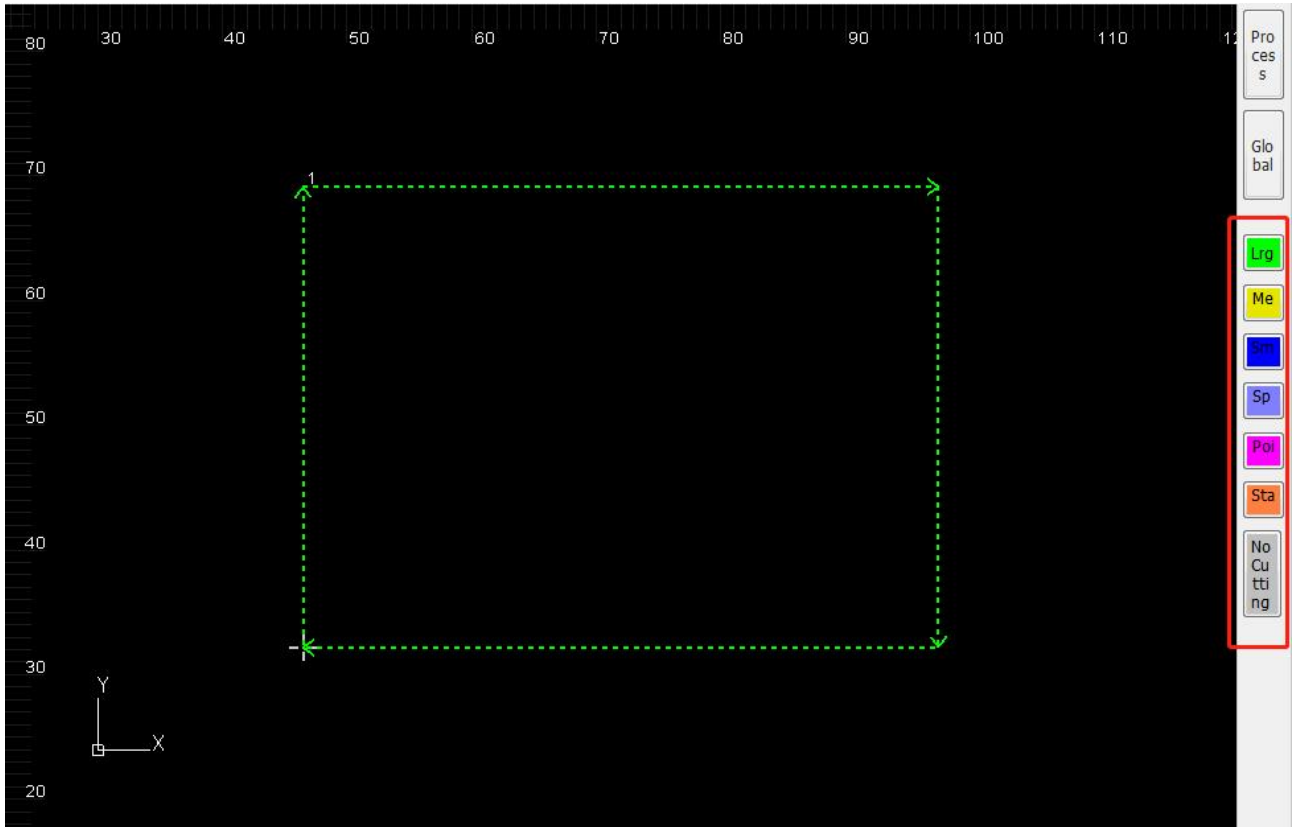

### 3.4 Processing Mode

Processing Mode	
<b>Defilm</b>	After selecting the function, the process is first carried out along the cutting path using the film parameters to defilm, and then carried out the normal process according to the layer parameters. Select the function and you can set the defilm parameter in the FilmCut interface.
<b>Prepierce</b>	Selecting the function, prepierce at the start of the graphic or the start point of the leadline, before actual cutting. There is also a function of auto-group prepiercing which can be selected in the global parameter.
<b>Processing mode</b>	Select standard or fixed height cutting. Fixed height cutting refers to cutting at a fixed height.

### 3.5 Cutting Parameter

Cutting Parameter	
<b>Nozzle height</b>	Set the cutting height from the nozzle to the plate.
<b>Speed</b>	Set the command speed of cutting.
<b>Power</b>	Set the peak power of the laser in cutting.
<b>Cut freq</b>	Set the frequency of the laser in cutting. It refers to the time of beam out in 1 second. The higher the value, the more continuous the laser beam is. 5000Hz is a successive beam.
<b>Duty cycle</b>	Set the duty cycle of the laser in cutting. It refers to the ratio of beam-out duration in one beam-out cycle and the total time. The higher the ratio value, the higher the average power is when beam out. When it is 100%, it means the average power equals the peak power.
<b>Gas pressure</b>	Set the assist gas pressure in cutting.
<b>Gas type</b>	Set the assist gas type. There are the air, oxygen, and nitrogen.
<b>Laser-on delay</b>	Set the delay at the start point of graphic processing to make cutting effect better.

### 3.6 Other Parameters

Other Parameters	
<b>Slow start</b>	Select to use the slow start function.
<b>Length</b>	The range of distance at which the slow start takes effect, starting from the start of the contour and including the leadline. Use to avoid not penetrating in cutting thick plates.
<b>Speed</b>	Set the slow start speed.
<b>Slow stop</b>	Select to use the slow stop function.
<b>Length</b>	Set the distance from slow stop starting to the end of cutting path.
<b>Speed</b>	Set the cutting speed when using slow stop function.
<b>Duty</b>	Set the duty cycle of laser beam out when slow stopping.
<b>Pulse freq</b>	Set the laser frequency when slow stopping.
<b>Beam off early</b>	The distance to turn the beam off in advance before reaching the end of cutting path.
<b>Control mode</b>	Set the control mode of slow stop.

### 3.7 Power Curve

Select the corresponding options to display the laser output in curve.

There are two power - speed curves, Duty cycle and Frequency. Users can select any option for needs. It is suggested to select the Duty cycle curve only, which has an obvious effect and is easy to adjust.

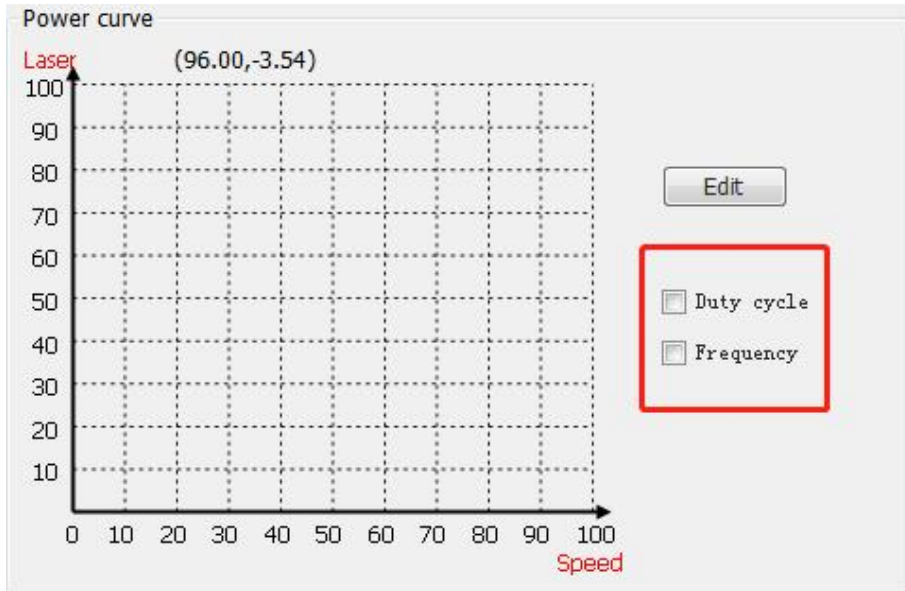

Click on Edit button to edit the curves in another interface, as shown below:

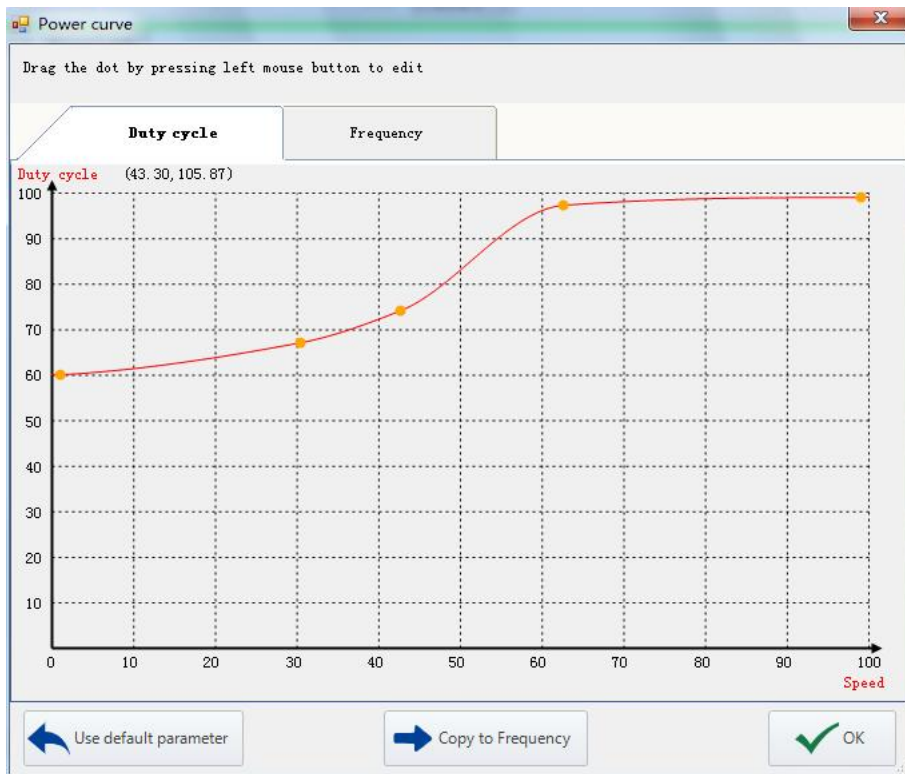

The power curve is fitted as a spline curve, with the horizontal coordinate being the speed and the vertical coordinate being the laser output, which has good smoothness. The interfaces for editing can be chosen as shown above.

Take the figure above as an example: the duty cycle is 60%-70% when the speed is about 30%, and nearly 100% when the speed is 100%. As in the processing, the duty cycle is nearly 100% for a cutting speed of 10m/min, the duty cycle is 60%-70% for a cutting speed of about 3m/min.

The default parameter meets most needs in processing. Users can fine-tune the curve base on the default.

### 3.8 Piercing

Piercing Parameter	
<b>Smooth Pierce</b>	Select to use the noninductive piercing. Height: set the height of the nozzle from the plate. Time: set the time for noninductive piercing. Focus point: set the focus point for noninductive piercing. Laser adjmt.: select to adjust the beam-out parameter for noninductive piercing. Power: set the laser power for noninductive piercing. Duty: set the duty cycle for noninductive piercing. Frequency: set the laser frequency for noninductive piercing.
<b>Pierce level</b>	The piercing is sequential down from level 5 to level 1 and can not be selected across levels. The sequence of piercing is five - four - three - two - one.
<b>Pierce type</b>	Segment pierce: the height of nozzle from the plate is fixed during piercing. Follow pierce: the height of nozzle from the plate changes at a constant speed to the piercing height of next level. Lightning pierce: the height of nozzle from the plate is fixed and the frequency and duty cycle can be changed at a constant speed during piercing.
<b>Pierce time</b>	Set the piercing time.
<b>Nozzle height</b>	Set the height of the nozzle from the plate during piercing.
<b>Gas type</b>	Set the assist gas type for piercing. There are the air, oxygen, and nitrogen.
<b>Gas pressure</b>	Set the assist gas pressure for piercing.
<b>Extra blow</b>	The pressure of nozzle cooling gas for piercing.
<b>Power</b>	Set the peak power of the laser in piercing.
<b>Frequency</b>	Set the beam-out frequency in piercing.
<b>Duty cycle</b>	Set the beam-out duty cycle of the laser in piercing. It refers to the ratio of beam-out duration in one beam-out cycle and the total time. The higher the ratio value, the higher the average power is when beam out. When it is 100%, it means the average power equals the peak power.
<b>Start Focus</b>	Set the focus position when start piercing.
<b>Extra blow (ms)</b>	It refers to the time of no laser and blowing gas only for cooling the plate after piercing.

<b>Extra blow</b>	Set the assist gas type for piercing. There are the air, oxygen, and nitrogen.
<b>Extra blow (bar)</b>	It refers to the time of no laser and blowing gas only for cooling the plate after piercing, which reduces the impact of the plate hotting to the next process.

### 3.9 Advanced Parameter

Click on Adv. next to Cut and Pierce. There will display the interface of setting advanced parameters, as shown below:

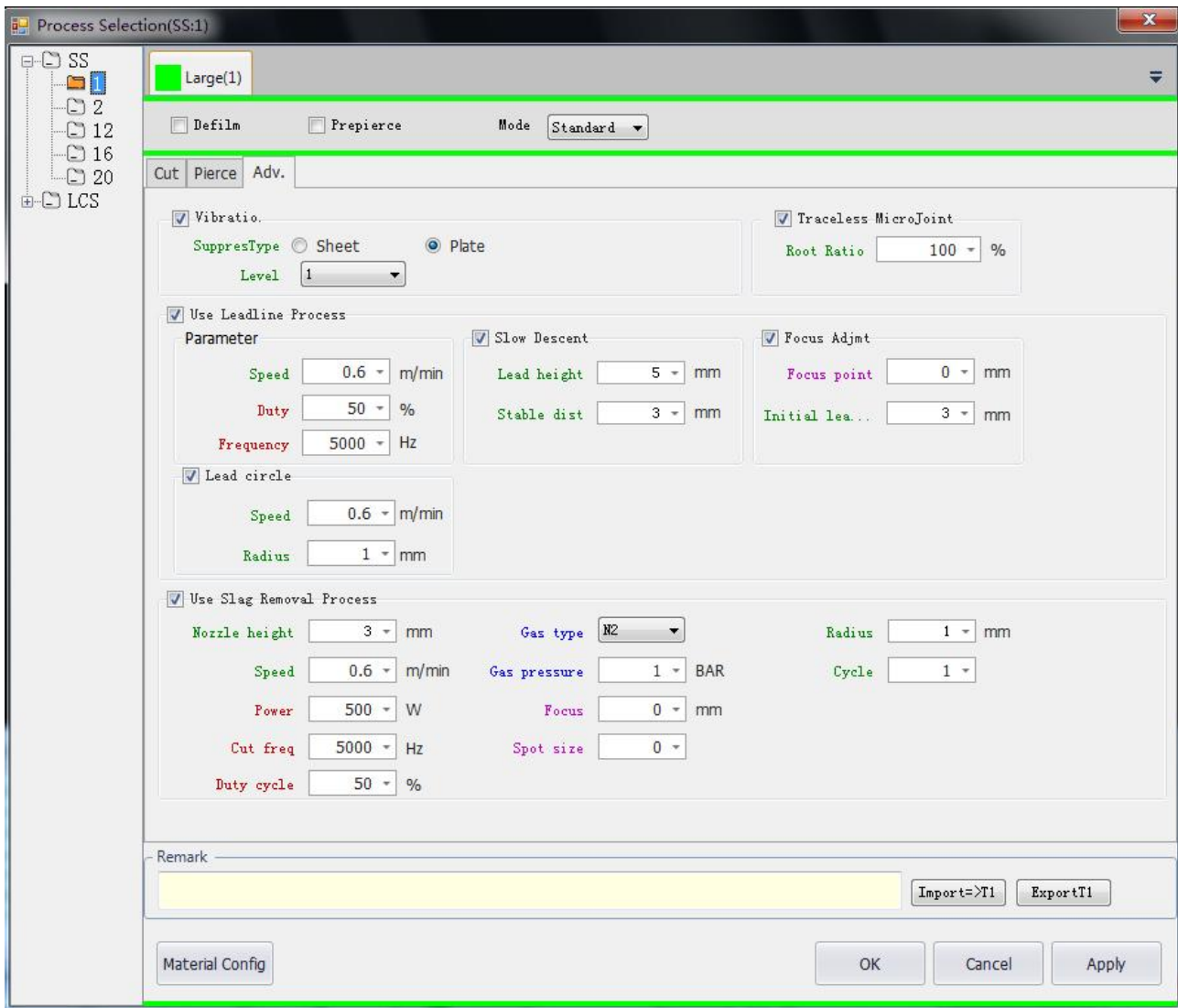

<b>Advanced Parameter</b>	
<b>Vibration (Vibratio.) Suppression</b>	There may leave slags on the plate after piercing a thick plate. The vibration suppression can improve the cutting effect.
<b>SuppresType</b>	The suppression is used for both thin and thick sheets. Please select the type according to your need.
<b>Level</b>	The higher the level of suppression, the slower the response is.

<b>Traceless MicroJoint</b>	Select to start using the traceless microjoint and make the thick plate not cut off at the joint in processing.
<b>Root Ratio</b>	Set the percentage of the retention left in cutting
<b>Leadline Process</b>	Select to use the leadline.
<b>Parameter</b>	Speed: set the cutting speed of graphic with leadlines. Duty: set the beam-out duty cycle when laser cutting with leadlines. Frequency: set the beam-out frequency when laser cutting with leadlines.
<b>Slow Descent</b>	select to descent slowly when cutting with leadlines.
<b>Slow Descent</b>	Lead height: set the nozzle height when cutting with leadlines. Stable dist: slowly descent the leadline height to the stable height of the plate in cutting. Set the stable distance of the leadline from the plate.
<b>Focus Adjmt</b>	Focus Adjmt: select to use the focus adjustment of leadlines. Focus point: set the focus position when cutting with leadlines. Initial leadline: set the initial length of leadline of focus-adjust cutting.
<b>Lead circle</b>	Lead circle: select to use the lead circle. Speed: set the processing speed of the lead circle. Radius: set the radius of the lead circle.
<b>Slag Removal Process</b>	Select to use the process to remove slags.
<b>Nozzle height</b>	Set the cutting height from the nozzle to the plate when removing slags.
<b>Speed</b>	Set the cutting speed when removing slags.
<b>Power</b>	Set the beam-out peak power of the laser when removing slags.
<b>Cut freq</b>	Set the beam-out frequency of the laser when removing slags. It refers to the time of beam out in 1 second. The higher the value, the more continuous the laser beam is.
<b>Duty cycle</b>	Set the beam-out duty cycle of the laser when removing slags. It refers to the ratio of beam-out duration in one beam-out cycle and the total time. The higher the ratio value, the higher the average power is when beam out. When it is 100%, the average power equals the peak power.
<b>Gas type</b>	Set the assist gas type when removing slags. There are the air, oxygen, and nitrogen.
<b>Gas pressure</b>	Set the assist gas pressure when removing slags.
<b>Focus</b>	Set the focus position when removing slags.
<b>Spot size</b>	Set the size of the laser beam when beam out in removing slags.
<b>Radius</b>	Set the radius of cutting nozzle when removing slags.
<b>Cycle</b>	Set the Circle of cutting nozzle when removing slags.

### 3.10 Remark

Users can input some notes of the current process and other relevant information, like the nozzle size, according to the needs in the Remark interface.

The image shows a software interface for entering remarks. It features a text input field with a yellow background, a label 'Remark' above it, and two buttons labeled 'Import T1' and 'Export T1' to the right of the input field.



### 3.11 Import and Export

To import or export the process parameters of the layer, users should note that the button will only use to import or export the process of the current layer. For example, if using both layers of large and medium contours, clicking on Export button in the layer of large contour will only export the process parameters of it. The same applies to the import. Select the needed layer and then import or export.

### 3.12 Global Parameter

Global parameter mainly includes Motion Control Parameter, Default Parameter, Unit Selection, Prepiercing and Defilm. Adjustment of these parameters will affect the stability of machine operation, processing effect and efficiency.

Motion Control Parameter		
Parameter	Default	Remark
Travel speed	30	The travel speed of the X/Y axis from one contour to another in cutting. (Set the X and Y axis to be the same or separate with different parameters at the bottom of Motion Control Parameter.)
Travel acc	6000	The travel acceleration of the X/Y axis from one contour to another in cutting. (Set the X and Y axis to be the same or separate with different parameters at the bottom of Motion Control Parameter.)
Travel acc time	100	The travel acceleration time of the X/Y axis from one contour to another in cutting. The more the time, the slower the acceleration, which brings less impact to the machine. The less the time, the faster the acceleration, which brings more impact to the machine. (Set the X and Y axis to be the same or separate with different parameters at the bottom of Motion Control Parameter.)
Frame speed	18	Set the speed of framing.
Cutting acceleration	5000	Cutting acceleration is the maximum speed of each axis motion when cutting and used in conjunction with the cutting speed.
Cutting acc time	100	The more the cutting acceleration time, the slower the acceleration, which brings less impact to the machine. The less the time, the faster the acceleration, which brings more impact to the machine.
Low pass filter coefficient	20	The default is fine, and modify it if there are any special circumstances.
Corner speed coefficient	1	The default is fine, and modify it if there are any special circumstances.
Arc speed coefficient	1	The default is fine, and modify it if there are any special circumstances.
XY axis travel setting	Same	Set the X and Y axis to be the same or separate with different parameters.

Default Parameter		
Parameter	Default	Remark
Gas on delay	200	Gas on and delay till the set time before laser on.
First gas on delay	400	Before cutting, there are air in the gas hose. So, it takes a while for the gas out before laser on to ensure stable cutting. Set the time of gas out.
Pre gas on	500	It refers to the time to open the gas in advance after processing starts.
Gas switch delay	200	When switching to another type of gas in cutting, gas on first and gas off delay before laser on and continue cutting.
Cooling delay time	1000	Set the time of stay on the cooling point.
Contour end closing	200	Set the delay of gas off at the end of cutting.
Contour end beam off	0	Set the delay of laser off at the end of cutting.

Gas Parameter		
Parameter	Default	Remark
Manual Air pressure	2	the air pressure of manual gas out
Manual Oxygen pressure	2	the oxygen pressure of manual gas out
Manual Nitrogen pressure	2	the Nitrogen pressure of manual gas out.
Use protective gas	Close	Open: open the protective gas and keep blowing once the system is enabled. Close: close the protective gas
Protective gas pressure	0.3	Set the pressure of protective gas.
Keep blowing	Close	When it is open, keep the gas on when travel in cutting for a longer lifespan of cover glasses.

Unit Selection		
Parameter	Default	Remark
Unit of Length	mm	"mm" and "inch" are available.
Unit of Time	ms	"ms" and "s" are available.
Unit of Speed	m/min	"m/min", "mm/s", "inch/min", and "inch/s" are available.
Unit of Acceleration	mm/s <sup>2</sup>	"mm/s <sup>2</sup> ", "inch/s <sup>2</sup> ", and "G(10m)/s <sup>2</sup> " are available.
Unit of Gas pressure	BAR	"BAR", "PSI" and "MPa" are available.
Unit of Power rating	W	"W" and "%" are available.

Advanced		
Parameter	Default	Remark
Power on delay:	2000	time of the machine enabled
Power control delay	6	Set the delay of the system power output.
Flycut control delay	0	Set the delay of the beam out when fly cutting.
Slag Removal Power Control	Deselect.	The control of power for slag removal is shown by the curve.

Prepiercing and Defilm:		
Parameter	Default	Remark
Prepiercing/Film type:	Group	Single Vector: select to process the single contours. Whole board: select to process the whole board. Group: select to process graphics in groups.
Sequence:	Prepiercing first	Prepiercing first: select to prepierce before defilming. Defilm first: select to defilm before prepiercing.

Z Coordinate Reset	
Parameter	Remark
Apply current Z coordinate	Click and set current Z coordinate as 0.

### 3.13 OK, Cancel and Apply

- **OK:** click on OK to save the process parameters set for the layer and make it effective.
- **Cancel:** click on Cancel and the parameters set for the layer will be ineffective with the interface closed.
- **Apply:** click on Apply after modifying the parameters for the layer. The parameters will be effective with the interface kept open.

### 3.14 Material Configuration

Click on Material Config button in the process interface.

The interface of material configuration will pop up as shown below:

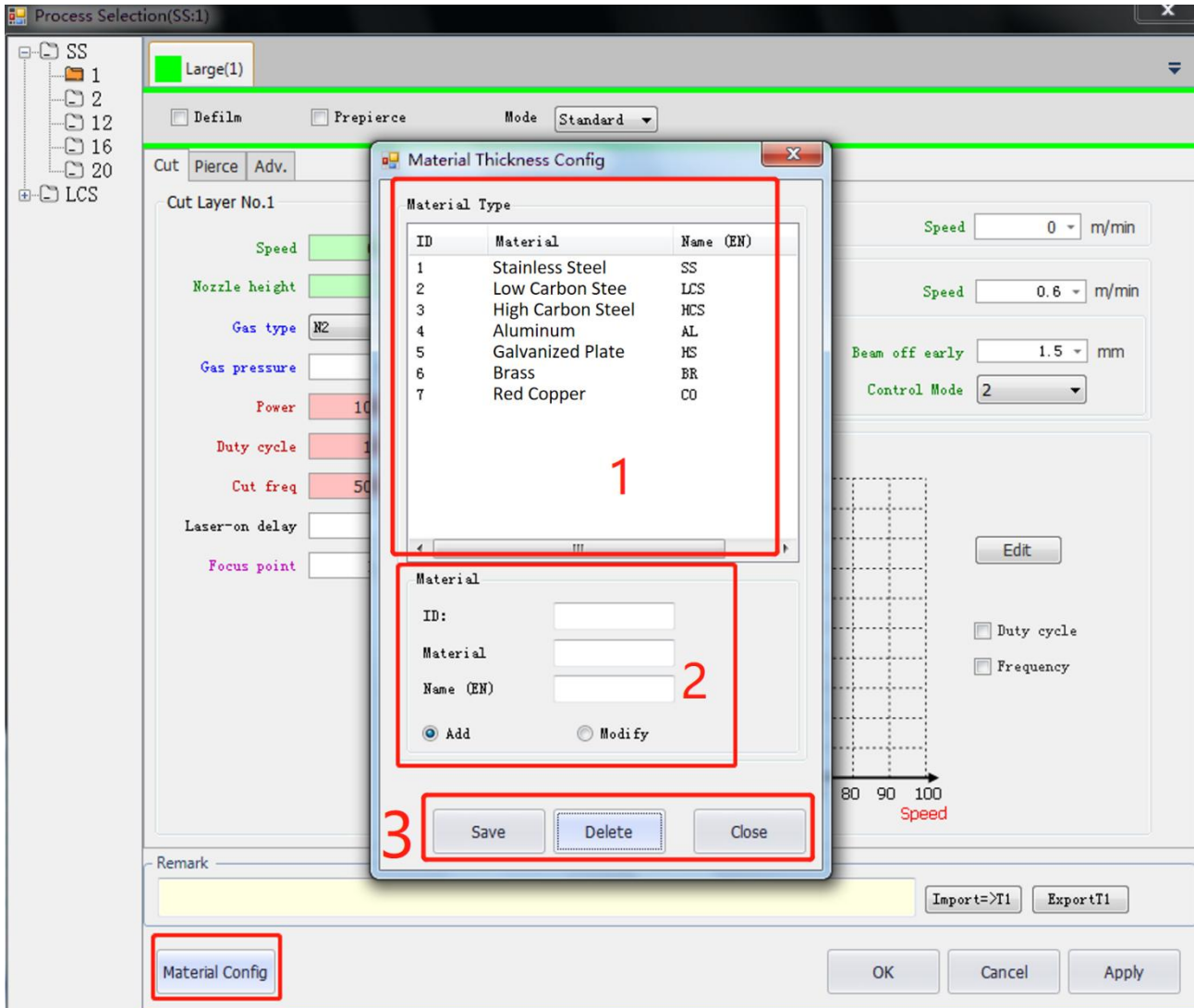

(1) There is a list of current materials. Users can add new materials.

(2) Add or modify the material.

(3) There are buttons of Save, Delete, and Close the interface.

The following is an example of adding a new type of material: **a.** Input the ID, Material, and its Name (EN as abbreviation). Then select Add button. Note that the ID and name of Material must not be the same as the existing materials, as follows:

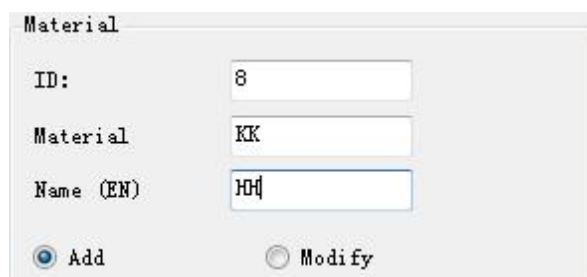

b. After inputting the information of the new material, click on Save button and Close button to complete and close the interface, as shown below:

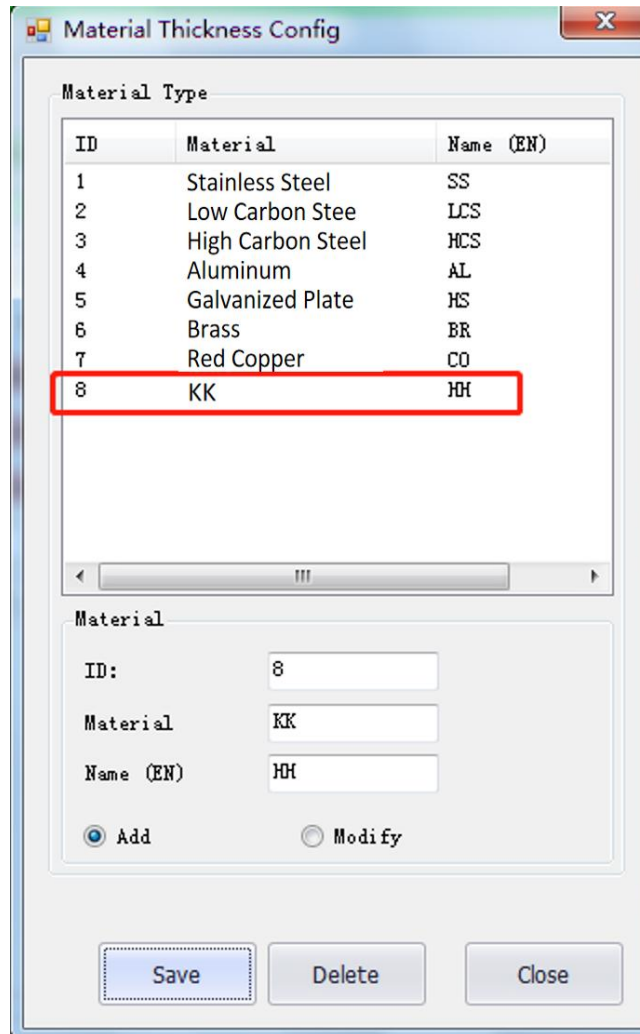

c. Refer to the operation instructed in 3.2 Tree-like Process Structure, the newly added material is selectable in the drop-down bar of choosing material type, as shown below. If the material is not need, you can delete it in the tree-like structure and delete in the material config later. In the material config, select the material in the list and click on delete button. Or, you may select it and click on Modify button to change it into another type of material with corresponding information. The operation on thickness of material is alike to the type, so it will not be repeated here.

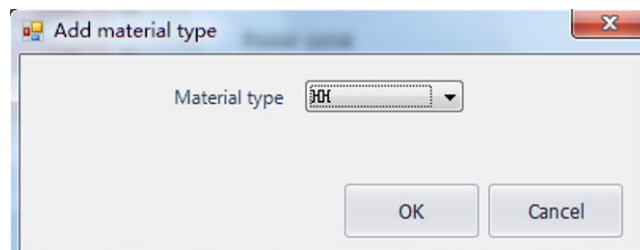

## 4 Control Panel

The processing control module mainly introduced in this chapter locates on the right of the drawing area. Functions are selectable in the control panel, such as the coordinate system, manual and auto control, etc.

### 4.1 Coordinate System

All the motions in processing are the cutting head relative to the workpiece. The workpiece zero, as part zero, is marked

as  in the drawing area. The correspondence between the machine coordinate systems and the workpiece coordinate system is shown below:

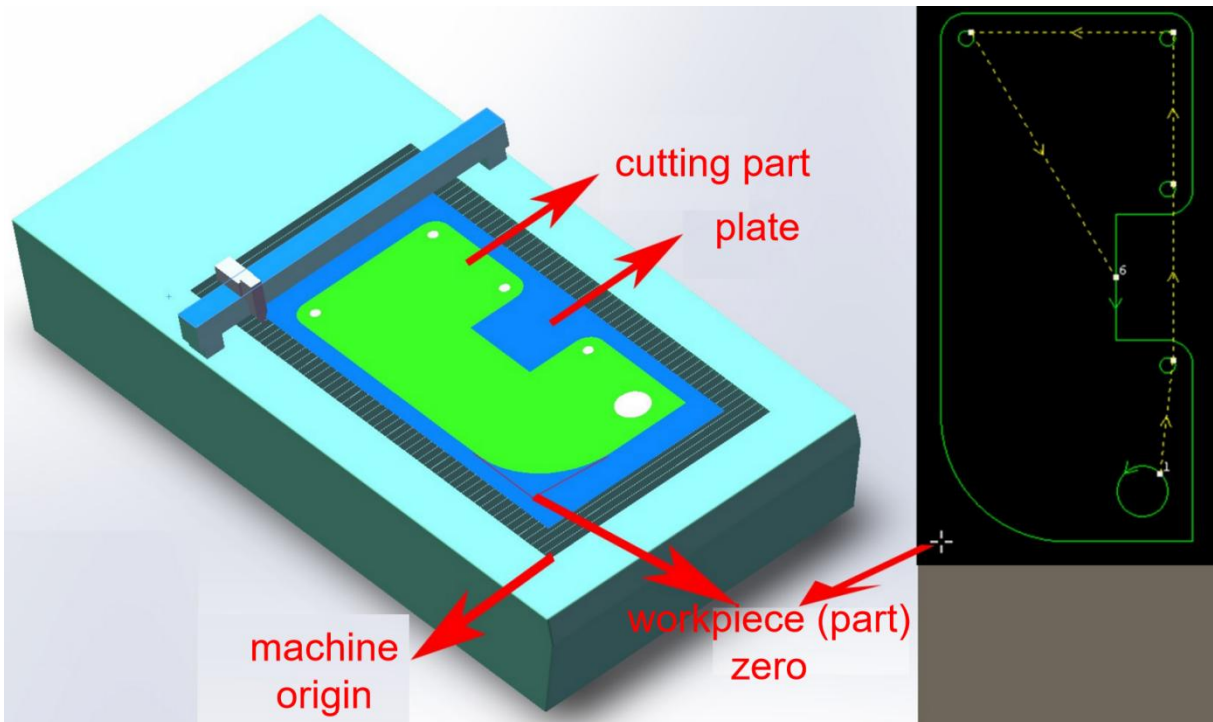

Click on Preview button in the control panel to display the positional relationship between the machine and graphic.

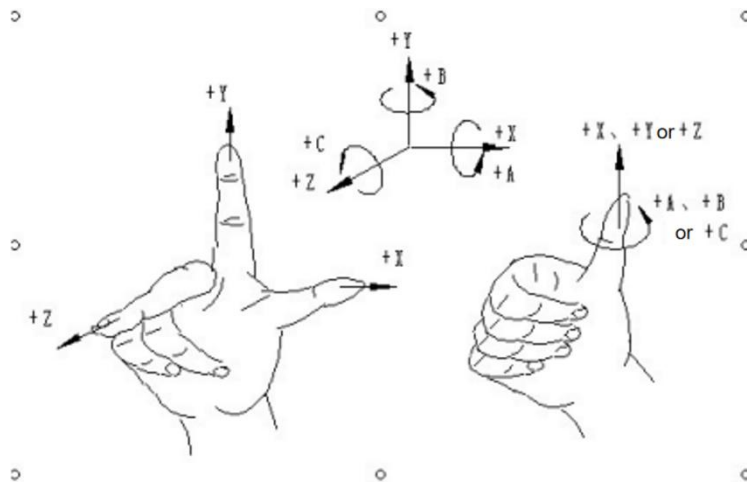

The coordinate system is the right-handed Cartesian coordinate system. As shown in the figure, the thumb is pointing in the positive direction of the X axis, the forefinger is pointing in the positive direction of the Y axis, and the middle finger is pointing in the positive direction of the Z axis. With the X, Y, and Z coordinates determined, it is easy to determine the direction of the A, B, and C rotational coordinates according to the right-hand spiral rule.

**4.1.1 Machine Coordinate System**

The machine coordinate system is only determined by the machine structure and its parameters. It can be established by clicking on Return Origin button, or by clicking on Return Origin button in the CNC sub-page to re-establish the machine coordinate system while initial installation or when there is any derivation for abnormal reasons.

**4.1.2 Program Coordinate System**

As the position of the workpiece may vary, it is necessary to introduce a workpiece coordinate system for ease of use. All the program coordinate systems in the software are identical in direction to the machine coordinate system. Only the zero point of the coordinate system is different, known as the program zero. The program coordinate system contains a floating coordinate and workpiece coordinates.

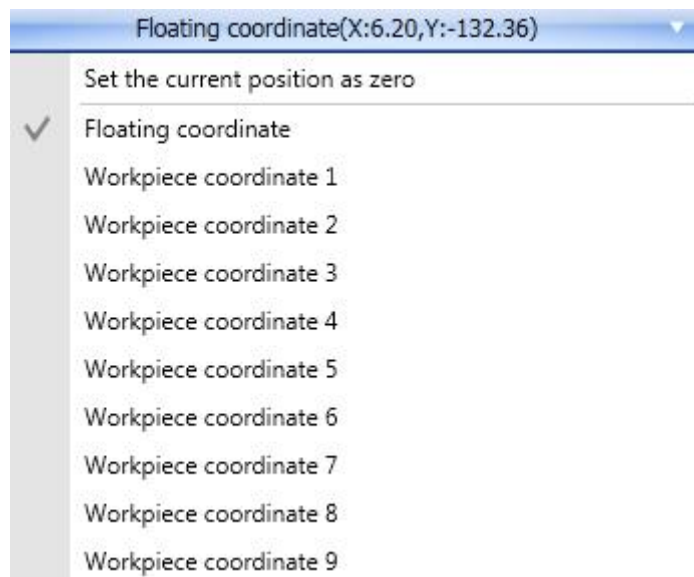

The button at the top of the control panel is used to select the floating coordinate system and other nine workpiece coordinate systems.

The floating coordinate system is generally used for informal processing and can be regarded as starting processing from wherever the laser head moves. The zero point of the floating system is automatically set to the current position of the laser head when the user clicks on Frame, Dry run, or Start button in the control panel, as shown below:

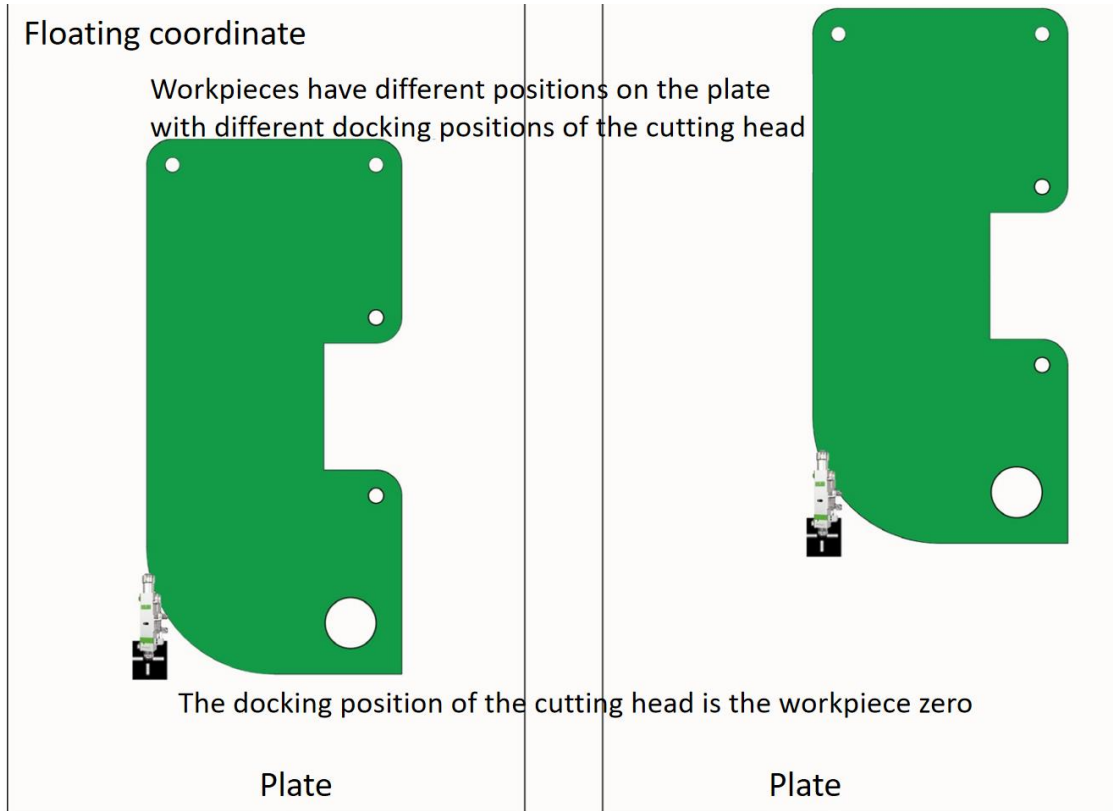



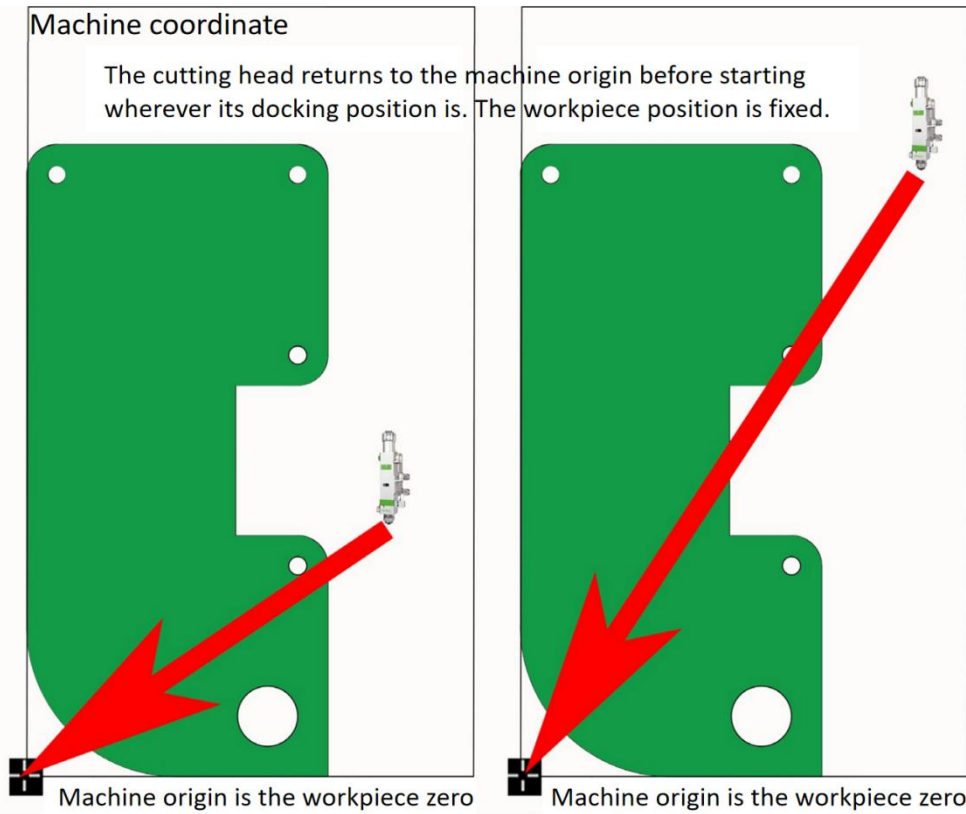

When selecting workpiece coordinate 1 to 9, the workpiece zero point is set manually by the user by clicking on Mark, and once set saved for a long time until the next setting. The workpiece coordinate system is suitable for batch production for the workpiece position is generally determined by a fixed fixture. Keep the processing in the same position each time by using workpiece coordinate 1 to 9 .

Click on the status bar at the bottom which is shown like



You can choose to display either machine (mechanical) or program coordinate and set the origin for both coordinate systems. Select "Set current point as program zero" to position the cutting head at the specified coordinates.

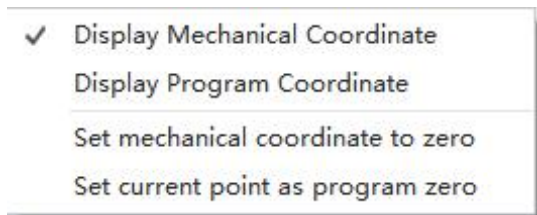

## 4.2 Manual Control



: click on Mark to mark the current point as the cutting head position.



: click on Go Marker and the cutting head will move to the marked point.



: 11 positions can be marked. Select the needed marked point in the drop-down bar.



: once the pin of the laser shutter connects to the system, click on Shutter to control the shutter switch.



: once the pin of the red laser light connects to the system, click on Aiming to control the red light.



: click on Laser to make the beam out to confirm the status of the laser beam. Set the laser parameters by clicking on the drop-down bar on its right.



: click on Follow to bring the cutting head to a distance of 1mm from the plate. Click on Follow again to cancel the following state and auto perform a Z-axis lifting.



: click on Blow to manually open or close the protective gas.



: Click on Nitrogen. Air, nitrogen, and oxygen are all selectable for blowing.

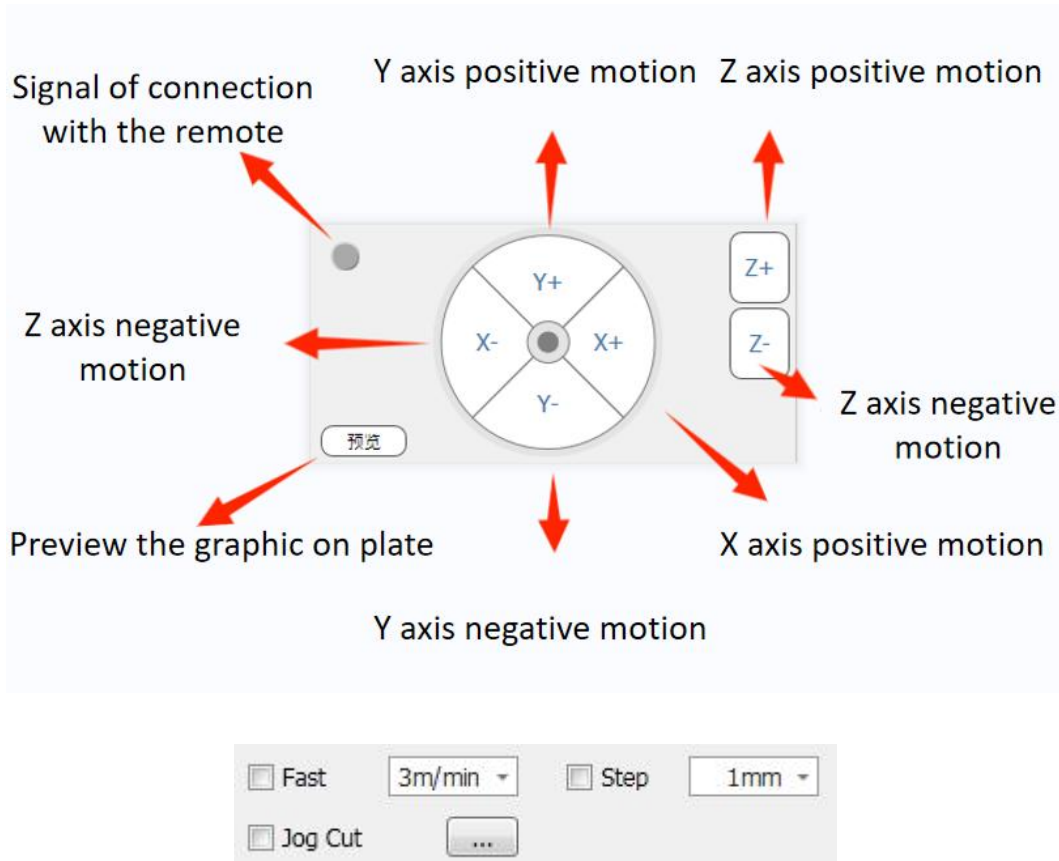

- **Fast:** after selecting and setting the speed, the axis motion will switch to the fast speed mode. Motion speed depends on the setting.
- **Step:** after selecting and setting the stepping distance, the axis steps when it's clicked to move. The stepping distance depends on the setting.
- **Jog Cut:** after selecting, click to move the axis and hold on. The cutting head will follow to move downwards and start cutting with beam out. Release the button for moving axis, and the jog cutting will stop. After each axis motion, the button will auto-deselect.

Click on  to open the setting of the jog cutting, as shown on the left:



Cutting speed: when the set processing speed is faster than it, it will be the maximum speed limit for jog cutting.

Stop ditch (Step height): the larger the value, the less sensitive the detection to the plate margin is, and the greater the Z-axis over move distance. The smaller the value, the more sensitive it is and the greater the probability of mistakenly detecting a plate undulation as its margin.

### 4.3 Processing Control

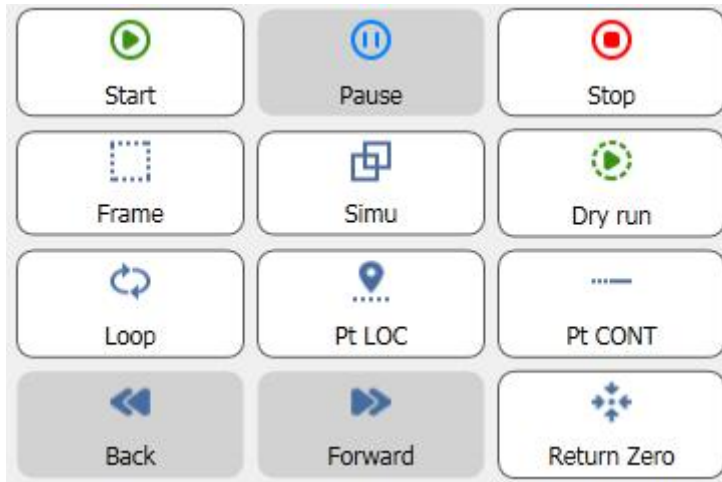

: click on Start to start the processing or resume if paused. After clicking on it, the mode interface will display auto-operating status.



: click on Pause when the program is running, and the auto processing will pause. The mode interface will display auto-paused status.



: click on Stop, and the processing will reset to the initial status and to be ready again.

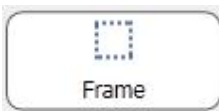

: click on Frame, and the cutting head will move along the outer contour of the graphic in a rectangle shape for users to observe the graphic position in the plate.



: simulate before processing. Click on Simu, and confirm the cutting path by simulation.



**Dry run**: dry run is different from the actual processing, with no laser, no gas, and no following-up, with other steps the same as the actual ones. If user clicks on pause while dry running and wants to continue to dry run, click on Dry run to resume the simulation. In paused status, clicking on Start leads to the actual processing from the position.



**Loop**: set the processing in loops at the position and click on Loop to see the following interface:

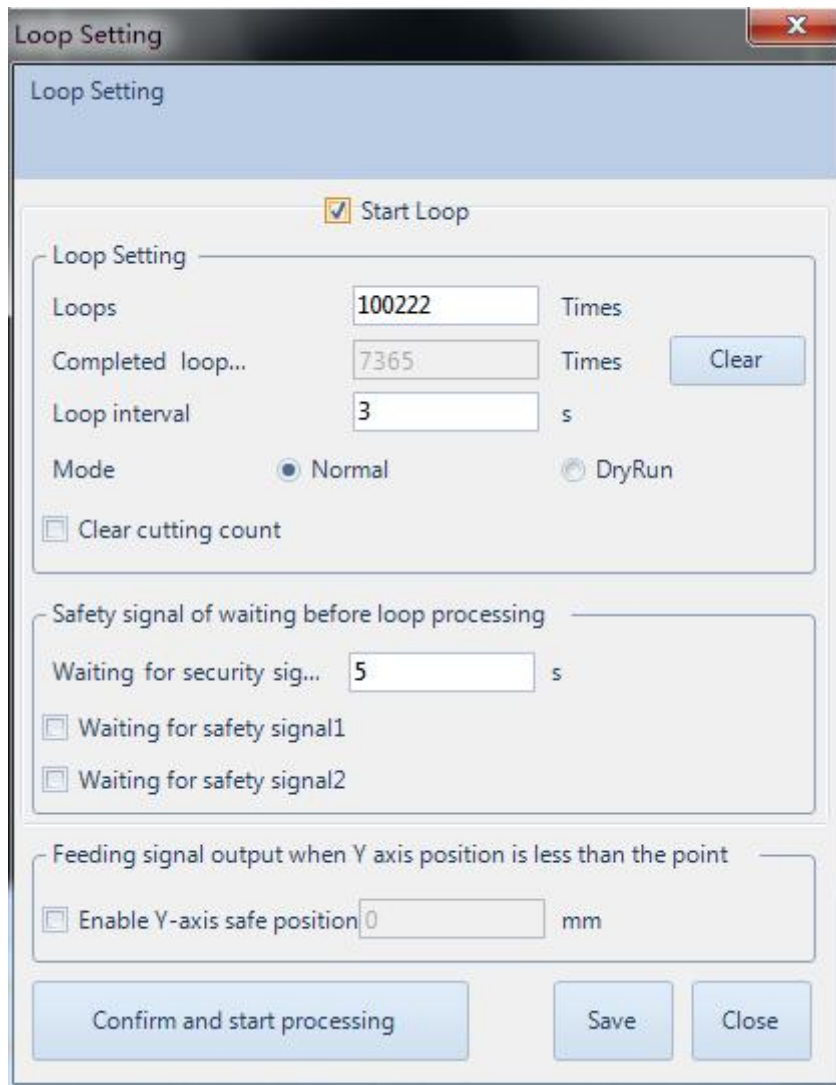

- **Start Loop**: select to start processing in loops.
- **Loops**: refer to the times of the processing before pausing.
- **Completed loop count**: display the count of completed loops in current program.
- **Clear**: clear the completed loop count and set as zero.
- **Loop interval**: refers to the time to wait after processing to start a new one.
- **Mode**: Normal refers to cutting and DryRun refers to run without beam, gas, or following-up. **Clear cutting count**: select to clear the previous processing count.



: only enter the breakpoint mode in paused state. In breakpoint mode, most functions in the control panel will be locked. User can move the cutting head by button for manual operating or wireless remote, or using the fixed-height.



: click on Pt CONT button, and the cutting head will move back to the located position and resume processing.

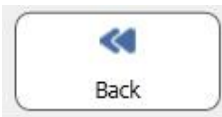

: click on the button in paused state, and the cutting head will move backward along the cutting path.

Click on Pause to stop the motion.



: click on the button in paused state, and the cutting head will move forward.

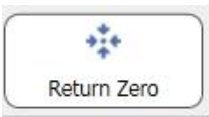

: click on the button to return to the machine origin. Note that right after opening the software, the first step is to return zero and then the functions in control panel will be activated.

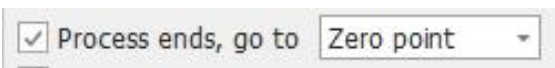

after selecting, at the end of the processing, the cutting head will auto-move back to the selected marked point.

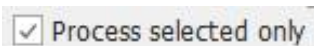

after selecting, click on the graphic in current drawing. And click on Start to process only the selected graphic.

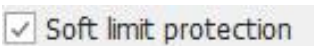

select to use the soft limit protection.

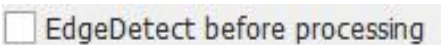

select to make the machine auto-detect edges before start processing.

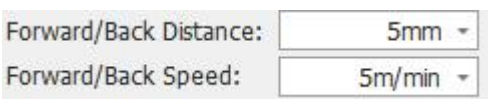

set the manual forward or backward motion distance and speed.

Count/Plan num15233/0 Manage

Count: count for each time of actual processing.

Plan: the actual count planned to be processed.

Click on Mange button in the processing control and there pops up an interface as shown below:



- **Total:** set the expected count of the workpiece to be processed.
- **Finished:** display the completed count.
- **Clear:** clear current completed count.
- **Aft task done:** there are corresponding prompts after the processing plan has been completed.
- **Pause:** select to pause the count of processing.

## 5 CNC Function

Click on CNC sub-page in the menu to see that there are Simulate, Follow-up, and Parameter of other functions, etc, as shown below:

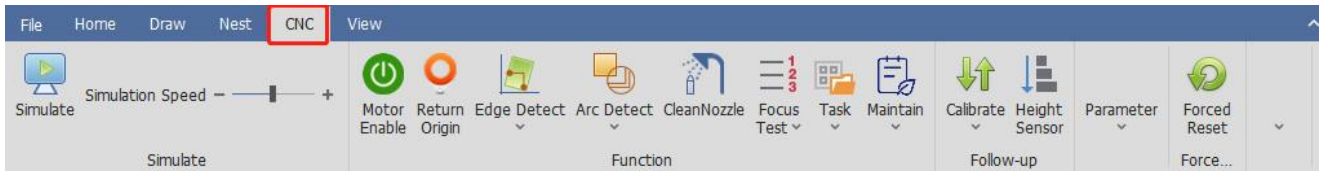

### 5.1 Simulate

Before processing, confirm the cutting path by simulation. Click on Simulate button in the CNC sub-page, and simulate cutting the current graphics. The simulation will be displayed in the drawing area, as shown below:

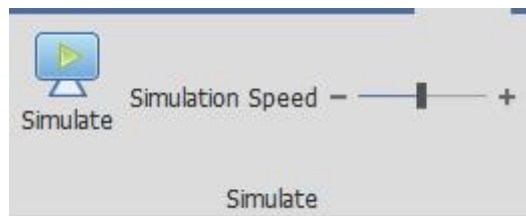

- **Simulation Speed:** the speed of the cutting simulation.

### 5.2 Motor Enable

The servo will be auto power-on when opening the software. Only with power can the machine work. Users can also click on Motor Enable to control.



### 5.3 Return Origin

After opening the software, it is needed to return origin first. Click on Return Origin button. The setting interface of will pop up as shown below:

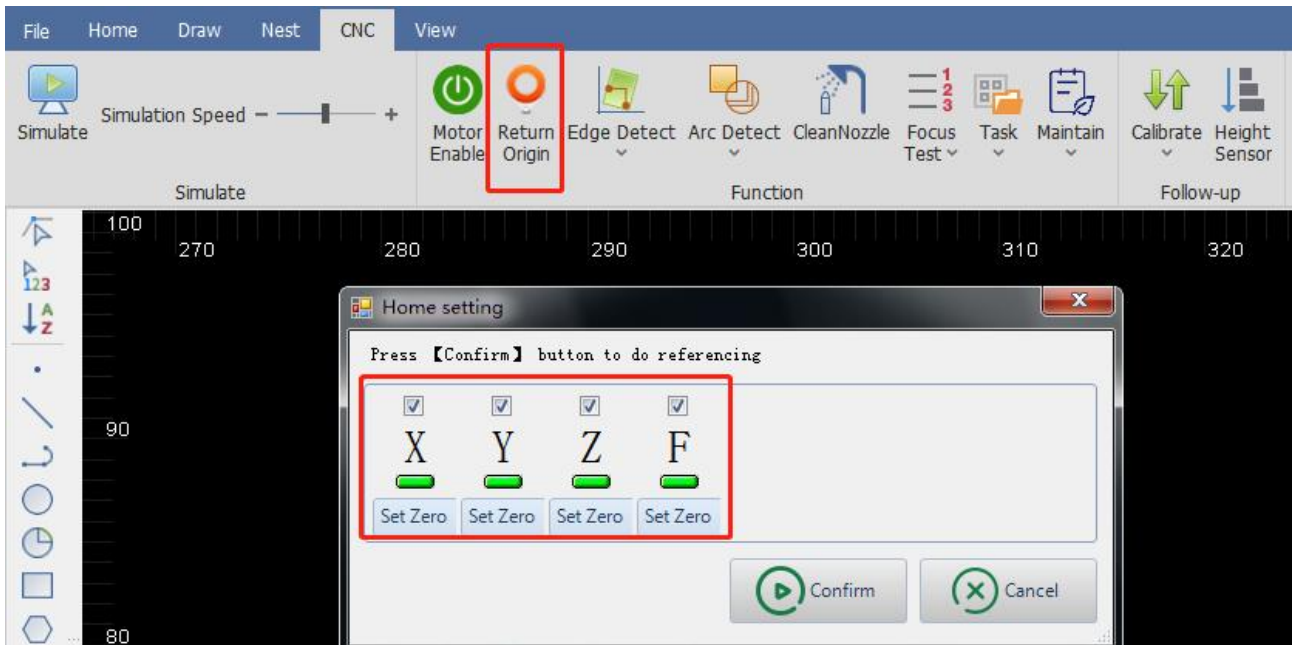

Select the axis to return origin and click on Confirm button. Then you can just wait for the motion of machine returning the origin.

### 5.4 Detect Edge

The way of edge detection includes auto, manual, and disc centering. Auto-detect edge by 3-point or 6-point.

- **Auto Edge Detection**

Click on the drop-down button under Edge Detect button in the CNC sub-page. Select Auto Edge Detect and the setting interface will pop up, as shown below:

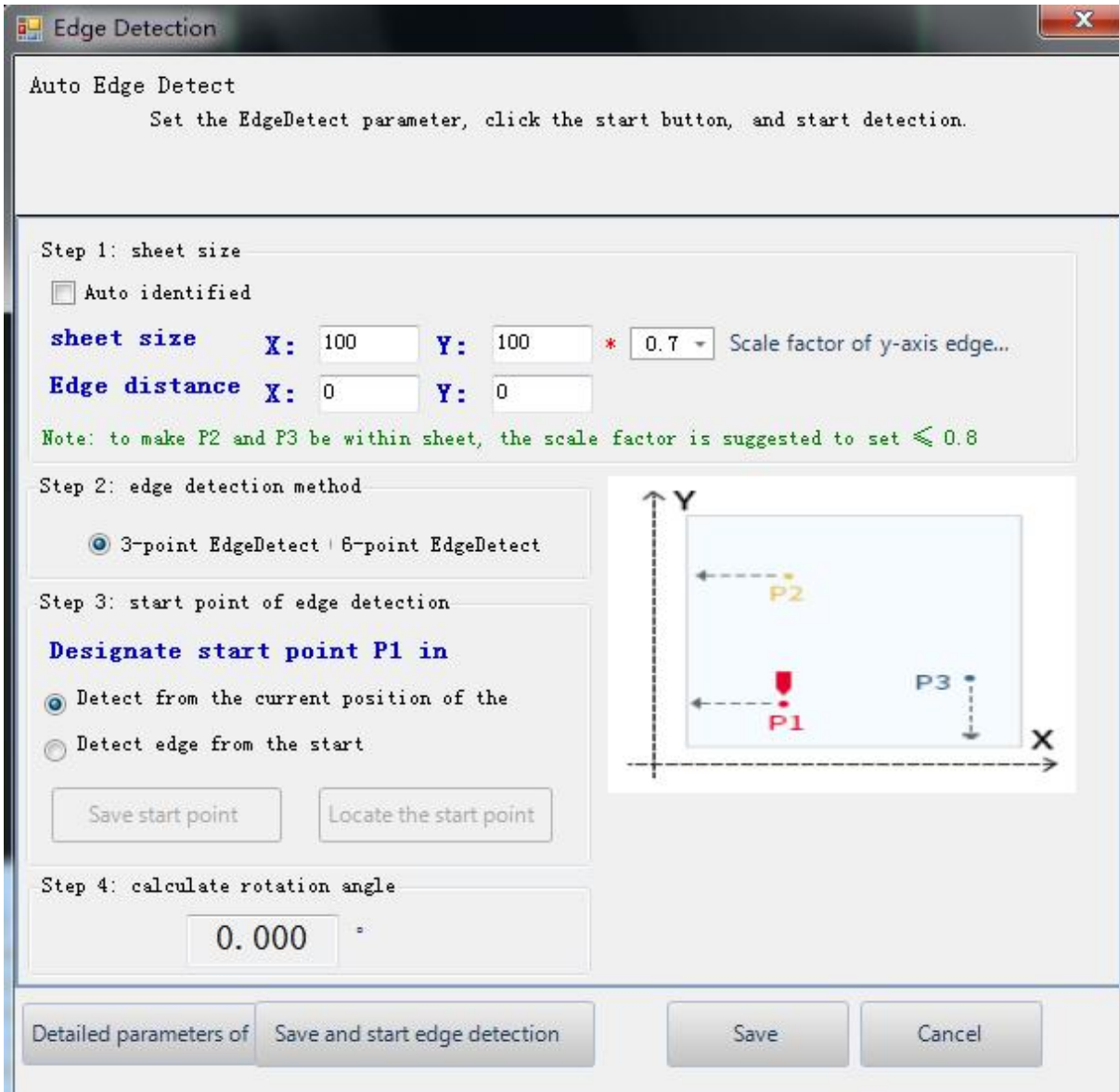

After completing the parameter setting, click on Save and start edge detection button, and the machine will start working. The result will be shown below the drawing area.

The following are the parameters for auto-detection:

- (Sheet size) **Auto identified**: select to auto calculate the sheet size after edge detection.
- **Sheet size**: X is the length of the sheet in X-axis direction of the machine. Y is the length of the sheet in Y-axis direction of the machine. Please note that inputting the wrong sheet size will risk sticking the cutting head. Please input the actual sheet size!
- **Edge distance**: set the positional deviation of Point P for edge detection. A positive value shifts the zero point of the sheet inwards, a negative value outwards.
- **Edge detection method**: 3-point and 6-point. It is suggested to use the 6-point edge detection on the thin sheet. Detect the edge by a single point 6 times to avoid interference from the tooth tip to the edge detection on a thin sheet.

- **Detect from the current position of the cutting head:** select, and the edge detection will start from the current position of the cutting head. After selecting, please move the cutting head into the range of the sheet to make sure there is a sheet under cutting head.
  - **Detect edge from the start point:** select, and the edge detection will start from a fixed position. Move the cutting head into the range of the sheet and click on Save start point button. The current position of the cutting head will be recorded as a fixed position for detecting edge.
  - **Calculate rotation angle:** the rotation angle obtained by edge detection.
  - **Detailed parameters of edge detection:** Set the basic parameters for capacitive edge detection.
  - **Height:** the height from the cutting head to the plate in the process of edge detection.
  - **Step height:** the sensitive degree in edge detection. The higher the value, the less sensitive it is with greater Z-axis over-move distance. The smaller the value, the more sensitive it is with greater probability of mistakenly detecting a plate undulation as its margin.
  - **Speed:** set the speed of edge detection.
  - **XY-axis zero correction:** after edge detection, correct the edge detection result by setting a positive value to shift inwards and a negative value to shift outwards.
- Click on the drop-down button under Edge Detection. Select Clear Angle after Task Ends in the drop-down bar. The edge detection angle will be cleared each time after processing is completed.
  - Click on the drop-down button under Edge Detection. Select Clear EdgeDetect Angle in the drop-down bar. The current edge detection angle will be cleared.

### Manual Edge Detection

Click on the drop-down button under Edge Detect button in the CNC sub-page. Select Manual Edge Detect and the setting interface will pop up, as shown on the left:

According to the diagram, the plate is placed at an angle. Click on the button for axis movement to move to the X-axis edge.

Click on P1 to obtain the coordinate of Point 1. Click on the button for axis movement to move to another point on the X-axis edge. Click on P2 to obtain the coordinate of Point 2. Click on Calculate Angle, and the setting completes. The result will be shown below the drawing area, as shown below:

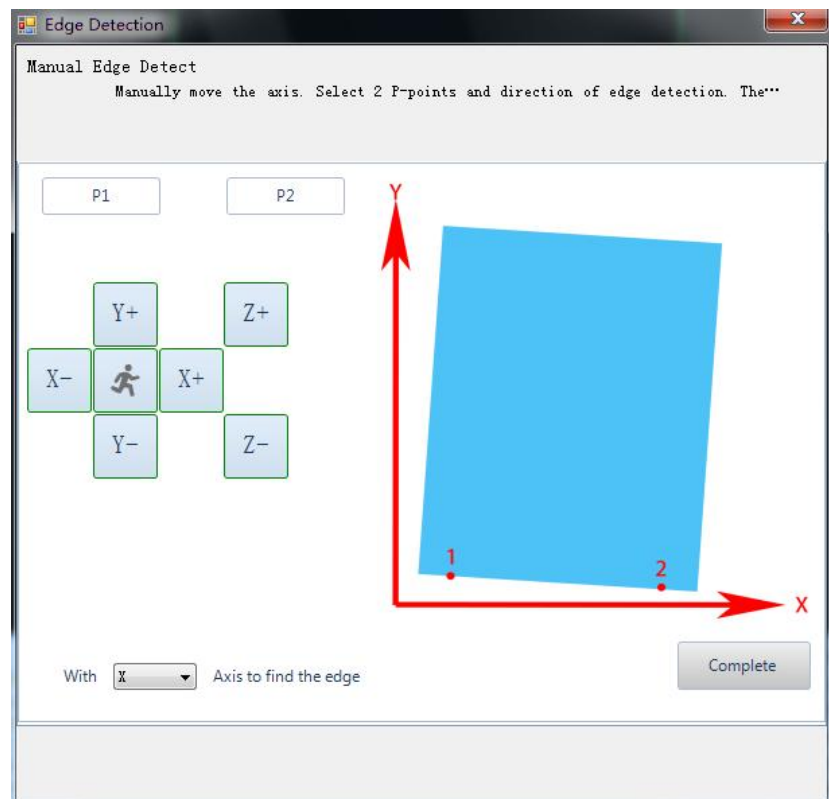

```
EdgeDetect Result:CCW rotation2.00 degree,Please note the difference between processing and display
```

### • Disc Centering

Click on the drop-down button under Edge Detect button in the CNC sub-page. Select Disc Centering and the setting interface will pop up, as shown below:

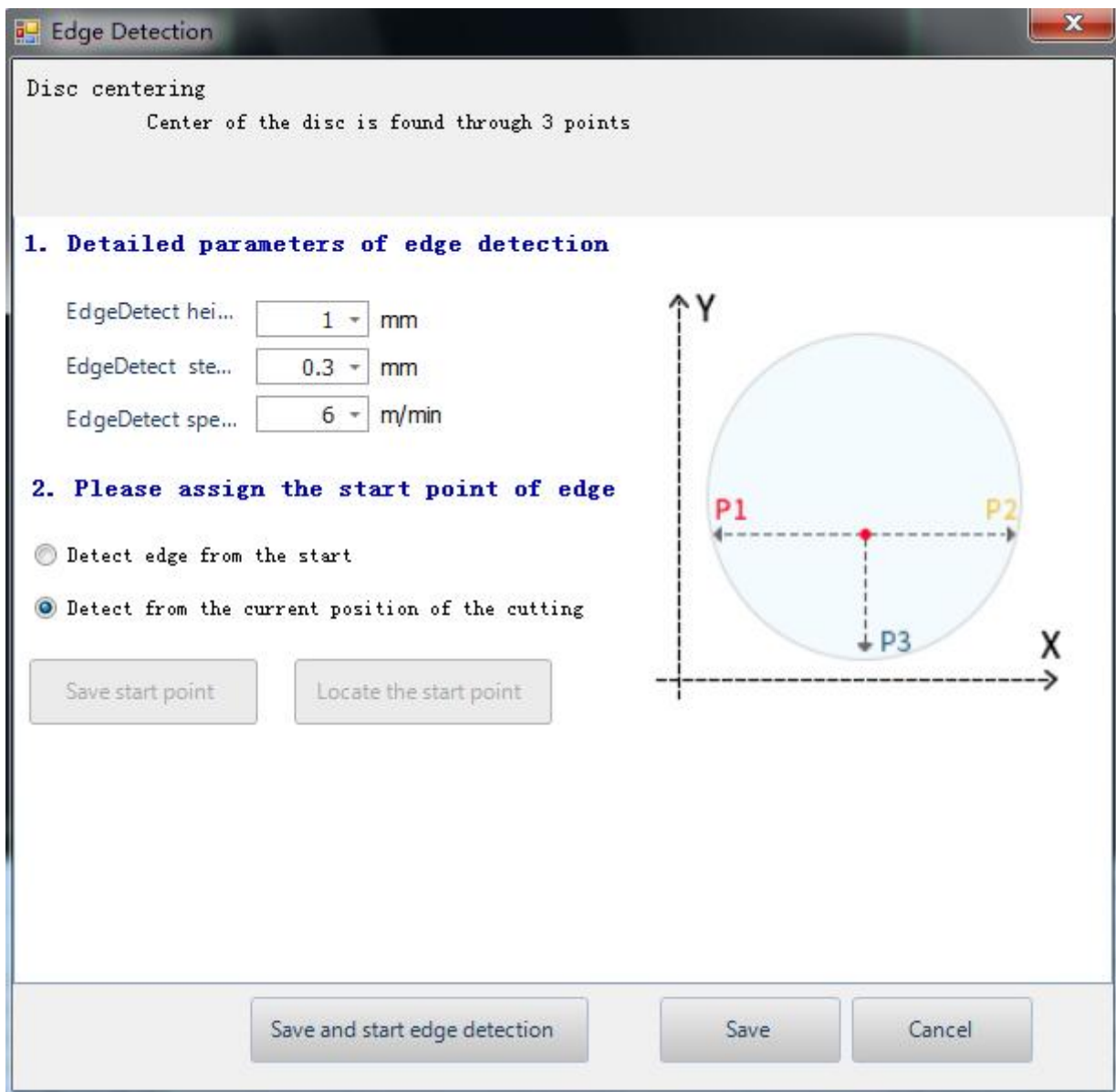

- **Height:** set the height from the cutting head to the plate in the process of edge detection.
- **Step height:** the sensitive degree in edge detection. The higher the value, the less sensitive it is with greater Z-axis over-move distance. The smaller the value, the more sensitive it is with greater probability of mistakenly detecting a plate undulation as its margin.
- **Speed:** set the speed of edge detection.
- **Detect edge from the start point:** select, and the edge detection will start from a fixed position. Move the cutting head into the range of the sheet and click on Save start point button. The current position of the cutting head will be recorded as a fixed position for detecting edge.
- **Detect from the current position of the cutting head:** select, and the edge detection will start from the current position of the cutting head. After selecting, please move the cutting head into the range of the sheet to make sure there is a sheet under cutting head.

- **History edge angle**

**Recover Edge Angle:** recover the edge detection angle used last time.

**Recover Edge Angle and Go Zero:** recover the edge detection angle used last time and return to the part zero.

**Set Edge Angle:** manually set a proper edge detection angle.

**Clear Angle after Task Ends:** auto-delete the edge detection angle after the process completes.

**Clear Edge Detect Angle:** manual-delete the edge detection angle.

- **Cut Off**

**Cut off in the X-axis direction:** select to detect edge in the X direction and cut off.

**Cut off in the Y-axis direction:** select to detect edge in the Y direction and cut off.

## 5.5 Arc Detect

Select to record the motion path in cutting next time. It can be opened when debugging servo parameters. The overlap between the actual motion track and the graphic can be used as a basis for debugging the servo parameters. Please do not use this function in normal processing.

## 5.6 Focus Test

The test is used to adjust the focus of the cutting head to be accurate. Click on Focus Test, and the height of cutting head in processing can be adjusted. Observe the cutting effect of the five lines and through analysis, the best is at the zero focus. It is recommended to use the 1mm thin plate which has a most obvious effect.

## 5.7 Task

If there comes an urgent order in the cutting process and the current graphics have not been completed yet, you can save the current process by clicking on Save button in the drop-down bar of Task button. And create a new drawing. After the urgent order is completed, click on Load In in the drop-down bar of Task button to import the processing file. Then the machine can resume the rest work and complete it. When any interference makes the machine stop processing, click on Restore Task before Power-off to resume the processing.

## 5.8 Power-on Prompt

The content of the power-on prompt is customizable.

## 5.9 Maintenance

Users can customize the maintenance prompt, the reminder period, to use the processing time or the system time for the reminder, to use the alarm or popup to remind, and the advance reminding time.

### 5.10 Capacitive Sensor

Click on the drop-down button of Calibrate in the CNC sub-page, and select Capacitive Sensor in Data Curve. The corresponding interface will pop up:

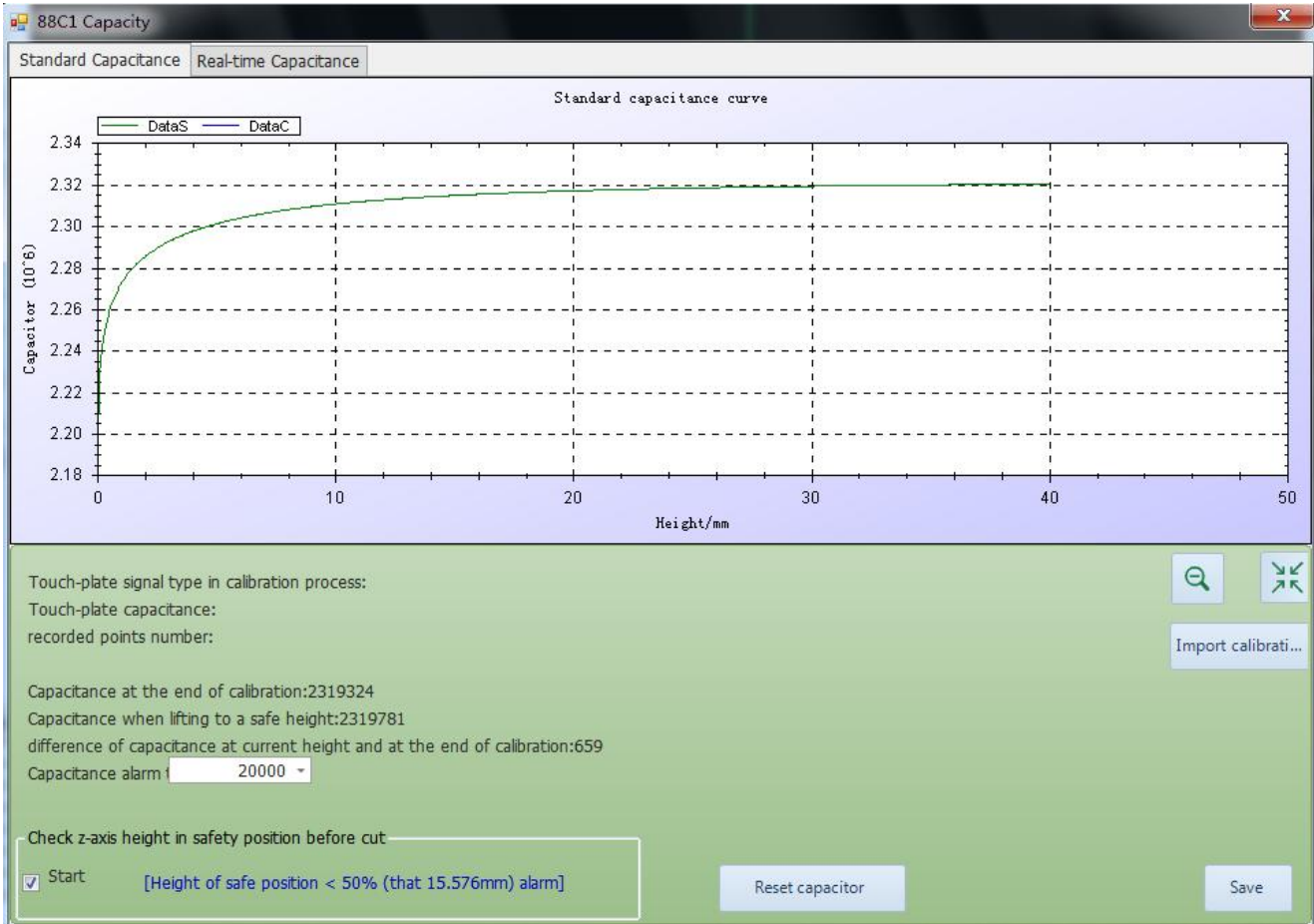

There displays information like capacitance curve and current capacitance. Click on Export calibration data to export the current data. Click on Reset capacitor to reset the current capacitance, and it's needed to calibrate again.

Click on the drop-down button of Calibrate in the CNC sub-page, and then the drop-down bar will pop up. At where there is the plate below the cutting head, click on Quick Calibrate button in the bar to calibrate the cutting head.

**5.11 Height Sensor**

Click on Height Sensor in CNC sub-page, and the setting interface which contains the following parameters will pop up:

Lifting		
Parameter	Default	Remark
Max lifting height (among contours)	30	After Z-Axis follow-up completes, the max lifting height is the lifting height of the cutting head bases on its current position. It is recommended not to set the value too large. The value can be set as half of the Z-axis travel. A value that is too larger may reduce the cutting efficiency.
Optimize short travel	Enable	Enable: use the function. Disable: not use the function.
Short travel	8	Using the function of optimizing short travel, if the linear distance between the end of the current contour and the start of the next contour is less than the value, the cutting head will move to the start of the next contour in the follow-up state.
Open LeapFrog	Enable	Enable: the cutting head will move and lift simultaneously while it completes cutting one contour and travels to the next one. When the cutting head gets close to the position, it will follow down in advance to improve efficiency. Disable: while the cutting head completes cutting one contour and travels to the next one, it will lift at first and then move to the start position of the next contour, and last it will follow down to reduce the risk of touching the plate.
Leapfrog takeoff height	0	It refers to the takeoff height of the Leapfrog function.
Max frog drop distance	20	It refers to the max distance when the cutting head frog-like drops.

Follow-up Parameter		
Parameter	Default	Remark
Follow level	7	The default is fine, and generally, it does not need modification.
Follow speed	18	It refers to the maximum speed when follow down.
Follow max height	5	If the follow height is larger than the value, the cutting head will follow up to 1mm from the plate and then lift to the follow height. Meanwhile, the follow-up is in closed state for the accuracy of height. If the follow height is smaller than the value, the cutting head will straightly follow-up to the follow height to improve the efficiency.
Real-time calibration	Select.	Optimize the algorithm at the set time to make the calibration data of capacitance more accurate.
Calibration jump value	1000	Select capacitance jump to be the touch-plate signal when calibrate, and the value will take effect. Parameter definition: during calibration, when the cutting head is seeking the plate, if the absolute value of the difference between the capacitance value of the current cycle and the capacitance value of the

		previous cycle (1ms ago) is greater than this value, the cutting head is considered to have touched plate, and at this time the cutting head moves upwards and starts the calibration to record the capacitance value in relation to the height.
<b>In place width</b>	0.2	It refers to the range of height used to decide if the cutting head follow-up is in place.
<b>Servo Feedback delay</b>	5	The delay can be auto-measured or adjusted by auto-tuning.
<b>Height sensor delay</b>	10	The delay can be auto-measured or adjusted by auto-tuning.

<b>Touch-Plate Parameter</b>		
<b>Parameter</b>	<b>Default</b>	<b>Remark</b>
<b>Piercing delay</b>	200	In piercing, the system will alarm and stop cutting if the duration of the touch-plate signal is greater than the value.
<b>Cutting delay</b>	100	In cutting, the system will alarm and stop cutting if the duration of the touch-plate signal is greater than the value.
<b>Dry run delay</b>	50	When the cutting head is in a dry run, the system will alarm and stop cutting if the duration of the touch-plate signal is greater than the value.
<b>Pre-touch-plate height</b>	0.1	If the current height is smaller than the value, it means the touch-plate signal is triggered. The function is used to protect the value, so it is fine to use the default value.
<b>Edge follow (to avoid touching plate)</b>	Disable	Enabled, once the cutting head is at the edge of the plate, it will prevent the cutting head shaking and touching plate.

<b>Axis Speed</b>		
<b>Parameter</b>	<b>Default</b>	<b>Remark</b>
<b>Speed</b>	1.8	The maximum speed limits the machine running. When the command speed is faster than it, refer to this value. Generally, it calculates by the max motor speed and pitch.
<b>Acceleration</b>	5000	It refers to the acceleration in cutting.
<b>Acc time</b>	100	The more the acceleration time, the slower the acceleration is, which brings less impact to the machine. The less the time, the faster the acceleration is, which brings more impact to the machine.

<b>Jog Speed</b>		
<b>Parameter</b>	<b>Default</b>	<b>Remark</b>
<b>Slow speed</b>	1.2	It refers to the axis speed when it is controlled manually.
<b>Rapid speed</b>	3	It refers to the axis speed when it is controlled manually in quick mode.



## 5.12 Lubrication

Click on Lubrication button in the CNC sub-page, and the setting interface will pop up. Users can check the time to do the next lubrication, or click on Oil Now to lubricate the machine at once, as shown below:

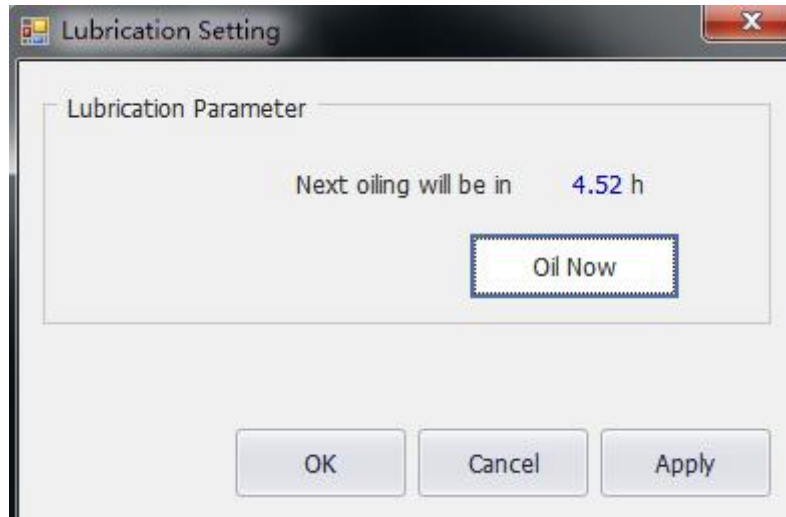

### 5.13 Dust Removal

Click on Dust Removal button in the CNC sub-page, and the setting interface will pop up. Users can set the function open or closed, and timed output. There are also selections for all on or all off, as shown below:

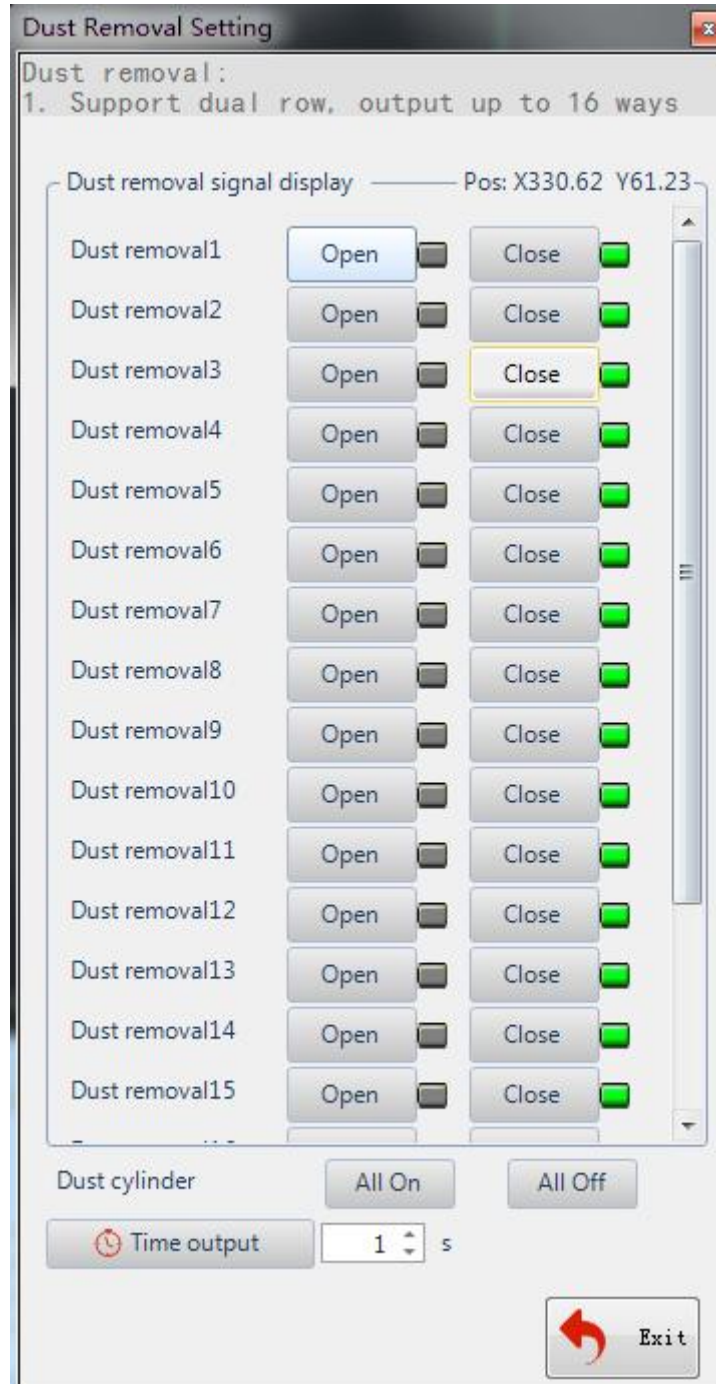

### 5.14 Setting

Click on Setting button in the CNC sub-page and its interface will pop up, as shown below:

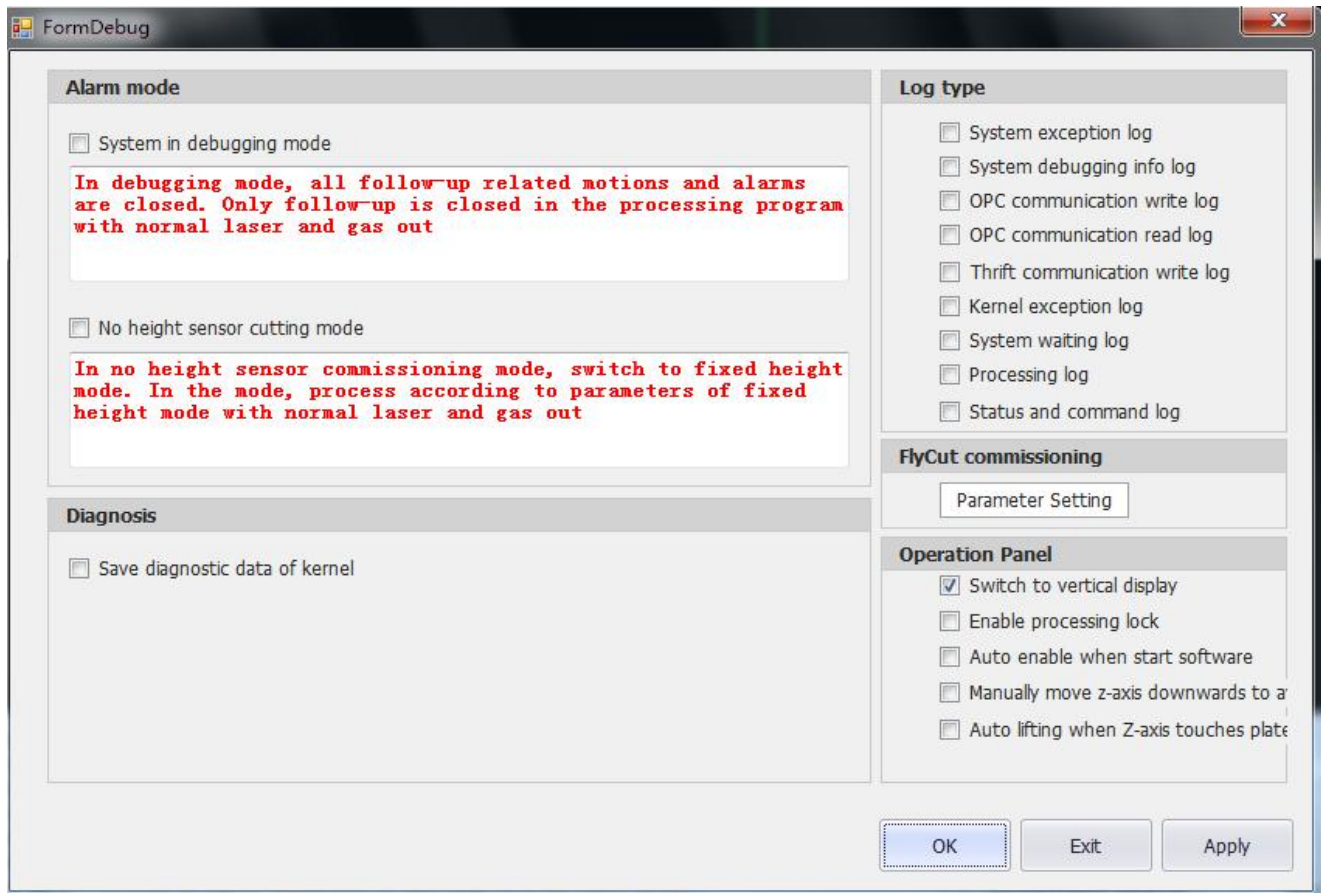

- **Alarm mode:** select or deselect according to the users’ needs while debugging. The default is to deselect.
- **Log type:** types of the log can be selected according to the users’ needs and viewed in the log area.
- **Fly Cut commissioning:** click on Parameter Setting to turn on the EDS2000 hardware for fly cutting. It’s also able to set the fine and coarse tuning of the pulse.

- **Control panel:**

**Switch to vertical display:** select to place the control panel at the bottom of the mainform. It is suitable for vertical display. The setting takes effect after re-open the software.

**Enable processing lock:** select to lock the control panel and make it ineffective.

**Auto enable when start software:** select to make the software auto-enable once opened. The software will not auto-enable if deselect the function.

**Manually move z-axis downwards to avoid touch plate:** turn on the touch-plate detection when Z axis moving.

**Auto lifting when Z-axis touches plate:** turn on the function of Z-axis lifting when touching plate.

### 5.15 Forced Reset

Click on Forced Reset to stop all the machine operations. Use the function for emergencies.

### 5.16 View Tread Info

Click on the drop-down button of Overview in the CNC sub-page. Select View Tread Info to see the system status.

### 5.17 View

The sub-page next to the CNC is View. Click on View to switch the language. The language setting takes effect after re-open the software.

## 6 Status Bar

The status bar at the bottom of the mainform mainly includes Draw (drawing log), Log (system log), and Alarm (system alarm). Click on the button to switch to view other logs, as follows:

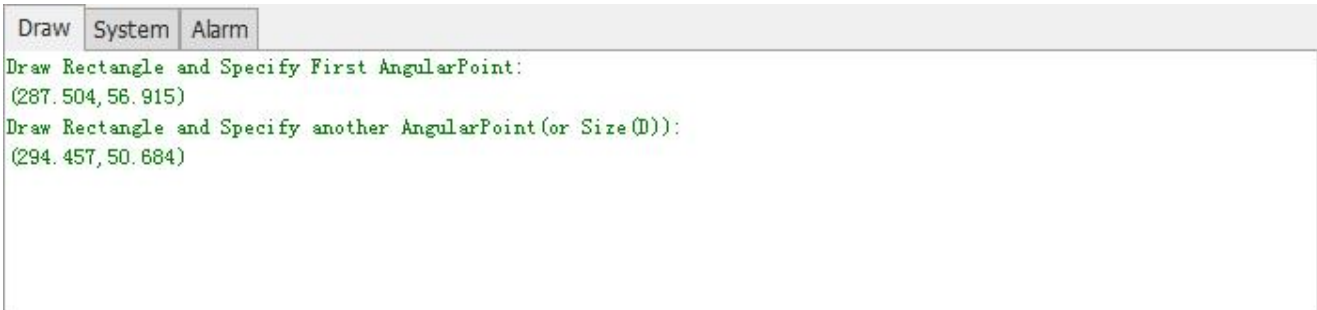

### 6.1 Draw

The drawing log reminds and leads the operations when the user is drawing or editing the graphics, as shown below:

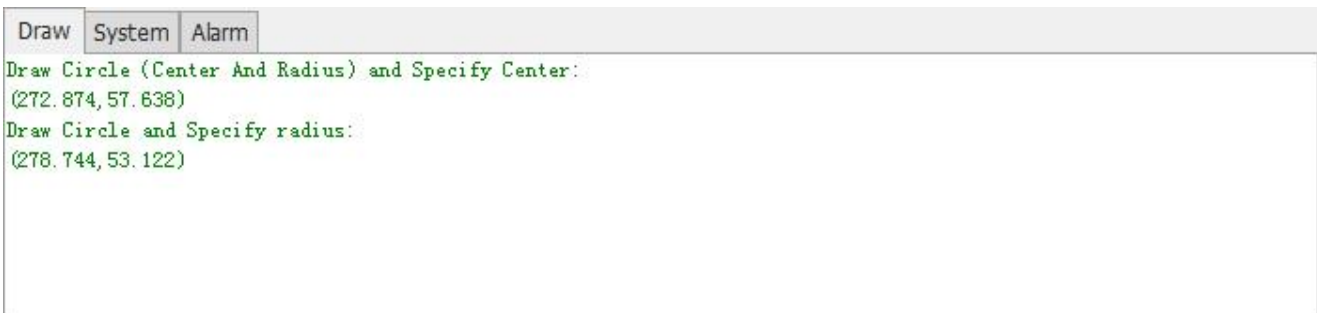

### 6.2 Log

The system log is mainly used to record the operations to the system, as shown below:



### 6.3 System

The system alarm is mainly used to display the current alarm or prompt, as shown below:

Draw	System	Alarm		
	Time	Alar...	Status	Message
!	13:12:05.412	20021	Active	Machine tool axis not all return to zero.
!	13:12:15.765	20017	Active	The system has detected that the height regulator is not calibrated. Please perfor...

**Note:** when a red alarm displays in the status bar, it is needed to clear the alarm before processing. If it is a grey or white prompt, it does not matter to the processing.